



MB220

Pram &
Pushchair

GB Instruction Manual

ES Manual de instrucciones



IMPORTANT, RETAIN FOR FUTURE REFERENCE: READ CAREFULLY

Welcome to the familiee

Your trust in our product means the world to us, and we're thrilled to be a part of your parenting journey. Our team has worked tirelessly to ensure that the MB220 provides comfort, safety, and style for you and your little one. We're confident it will exceed your expectations. Should you have any questions or require assistance in the future, please don't hesitate to reach out. Thank you for choosing My Babiie; we wish you and your family countless wonderful journeys ahead.

Get to know your MB220 Pram & Pushchair

Scan the QR code below on your camera app to be linked off to our page to get all the information you need for using your pushchair. From setting it up to how to fold it down, it's all there!



SCAN ME



Warranty

We provide a 1 year warranty against manufacturing or material defects. The warranty period is effective from the day of purchase and applicable to the UK and Ireland. If you made your purchase from an authorised retailer, please return your product to them.

If you bought your product via our website; mybabiie.com, please contact our Customer Service team via email (info@mybabiie.com). We are happy to refund any product if you change your mind about your purchase (if purchased from our website, mybabiie.com.) As long as you tell us within 30 days of receiving your goods. They must be returned in an unused condition, in the original, undamaged packaging and complete with all original parts and accessories. Proof of purchase is required.

What is not covered by the Guarantee?

- Failure to follow My Babiie user guide and maintenance instructions.
- Damage caused by non domestic use
- General wear and tear, for example: worn wheels, damaged rain covers, worn/tear fabric.
- Deliberate damage, misuse or neglect.
- Product which has been modified, undergone an unauthorised repair or used a non approved spare part.
- Cosmetic damage.
- Parts subject to normal wear and tear, foam handles, rubber elements of wheels, signs of fabric wear.
- Loss incurred as a result of not being able to use a product whilst waiting for a spare part or repair.

A repair service is available for any item that sustains accidental damage at any point during its lifespan. If the damages are not covered by our guarantee, we will provide a quote for the repair costs on an individual basis. If you find yourself in need of spare parts that are not covered by the warranty, you can purchase each spare part on our website (subject to availability).

To read more about your guarantee, please visit mybabiie.com/guarantee.

Our guarantee is provided by My Babiie Retail Ltd: Suite 188, Stockiie Business Centre, Unit A, St. James Business Park, Henwood Ind. Estate, Henwood, Ashford TN24 8DH

Your statutory rights are not affected by the guarantee.

Registering your Warranty

To register your warranty please visit www.mybabiie.com/warranties

Registering for your product warranty allows you to claim repairs or replacements if your product develops a fault. It will also help us contact you in the event of a product issue that you may need to be made aware of.

Problems or Questions

If you have any questions about your product then please drop us an email at info@mybabiie.com and we will get back to to you as soon as possible. Alternatively, you can chat to us on our Live Support Chat on our website mybabiie.com or contact us via our social media channels.

Pushchair warnings

IMPORTANT, RETAIN FOR FUTURE REFERENCE: READ CAREFULLY

Please read these instructions carefully before use and keep them for later reference.

Remove all packaging and non-permanent labels and dispose of safely before using this product. The safety of your child could be put at risk if you do not follow these instructions.

This stroller is designed for 1 child from 0 months up to a weight of 22 kg/36 months.

WARNING: Never carry or lift the seat unit or bassinet by the bumper bar with a child in

WARNING: Never leave your child unattended.

WARNING: Uneven or excessive loading of items on or in the stroller may cause the product to tip and may cause injury.

WARNING: Maximum intended weight within the shopping basket is 3kg.

WARNING: Ensure that all the locking devices are engaged before use.

WARNING: To avoid injury ensure that your child is kept away when unfolding and folding this stroller.

WARNING: Do not let your child play with this stroller.

WARNING: Always use the restraint system.

WARNING: Check that the pram body or seat attachment devices are correctly engaged before use.

WARNING: Do not put hot drinks or liquids in the cup holder.

WARNING: This product is not suitable for running or skating.

WARNING: Do not insert any additional mattresses into the stroller.

WARNING: Accessories which are not approved by the manufacturer shall not be used.

WARNING: This pushchair has been designed for one child and shall be used for the transport for only one child!

WARNING: Always use the crotch strap in combination with the waist belt.

WARNING: This stroller does not replace a cot or a bed. Should your child need to sleep, then they should be placed in a suitable cot or bed.

WARNING: Only replacement parts supplied or recommended by My Babiie shall be used.

WARNING: Any load attached to the handle and on the back of the backrest and on the sides of the stroller will affect the stability of the stroller.

WARNING: The parking device shall be engaged when placing and removing the children.

WARNING: Use the seat in the most reclined position for newborn children until they can support their own head.

WARNING: Only use the bassinet from 0-6 months / 9kg or when the child can start to left themselves up (which ever comes 1st)

EN 1888-1 & 2: 2018+A1: 2022 approved

Parts

Frame

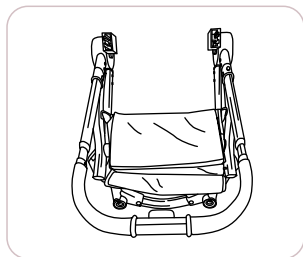

Canopy

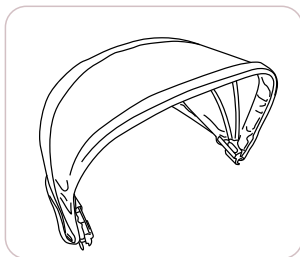

Bumper bar

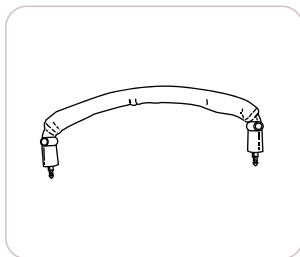

Front wheel (x2)

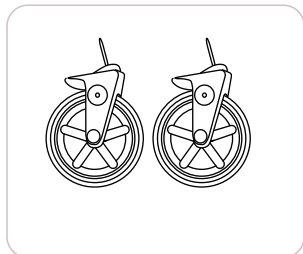

Rear wheel (x2)

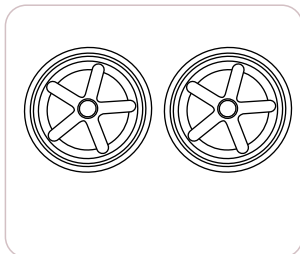

Seat unit



Bassinet insert



Footmuff

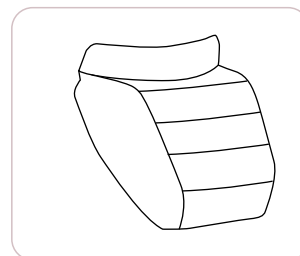

Harness

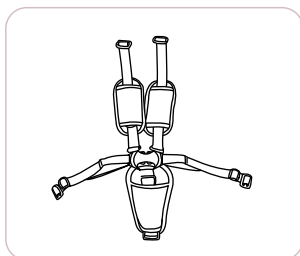

Bassinet cover

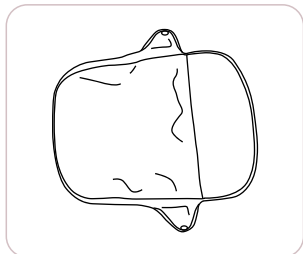

Raincover

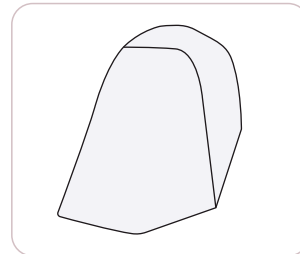

Car seat adapters

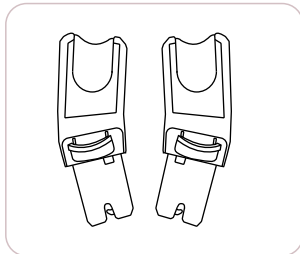

Open the frame

Open the frame in the direction of the arrow (as shown in Figures 1 and 2) until you hear a "click" (Figure 3). Then, ensure the frame is fully locked into place.

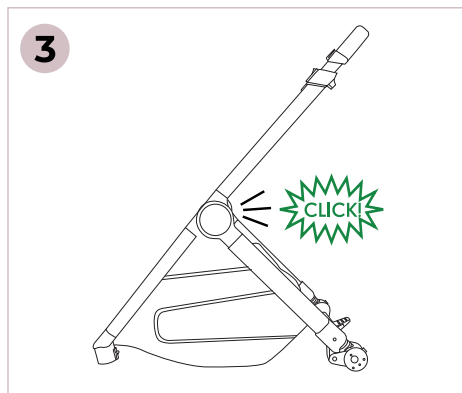
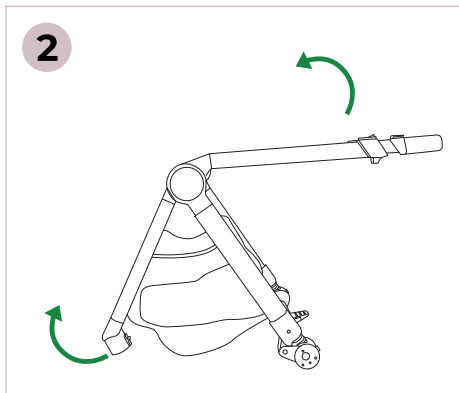
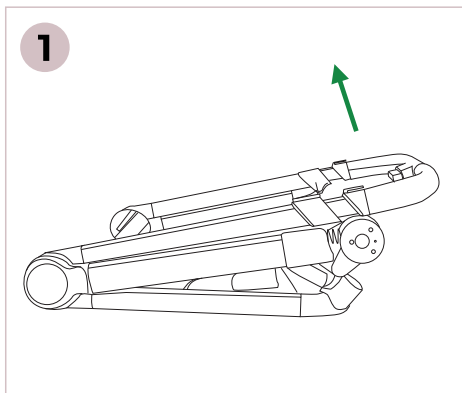

Install/remove front wheels

1

Align the plastic opening on the front wheel mounting bracket with the wheel, then insert the wheel until it clicks into place and is securely locked. Repeat the same steps for the other front wheel.

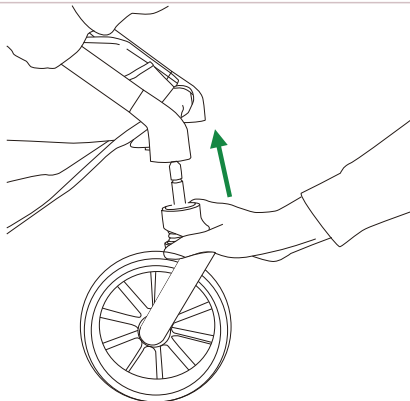

2

When the front wheel orientation lock is slid downward, the wheel is fixed and cannot rotate. Slide it upward to enable 360-degree rotation.

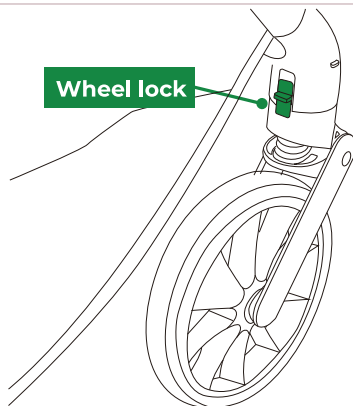

3

To remove the front wheel, press the small metal plate and gently pull the wheel out by hand. Repeat for the other front wheel.

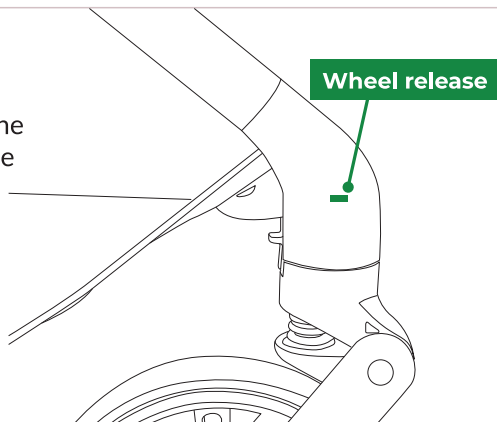

Install/remove rear wheels

1

Align the plastic hole on the rear wheel fixing seat and insert the wheel until it locks securely into place. Repeat this process for the other rear wheel.

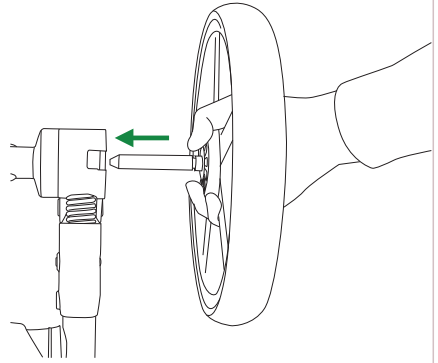

2

To remove the rear wheel, press down the locking metal plate and pull the wheel out. Remove the other rear wheel in the same way.

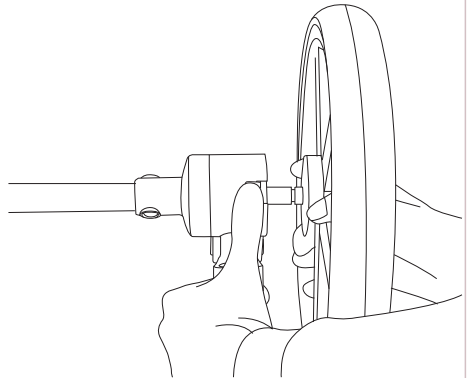

Bassinet assembly

1 Prepare the bassinet

Attach the velcro straps around the metal bar to secure it to the bassinet base.

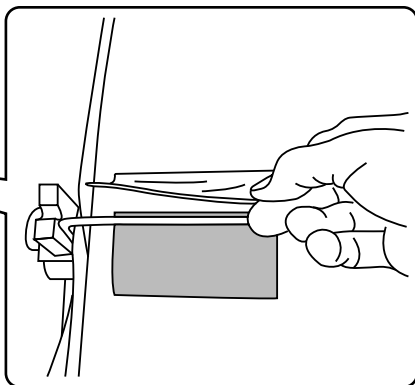
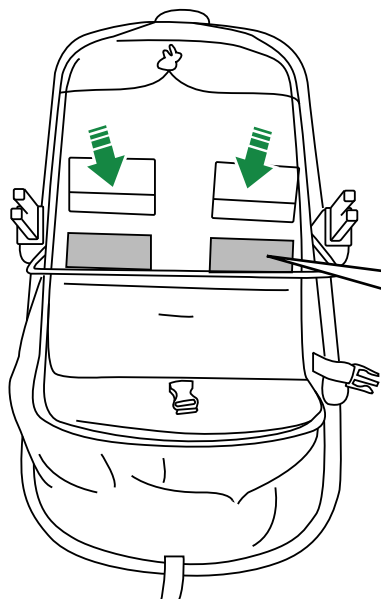

Secured base

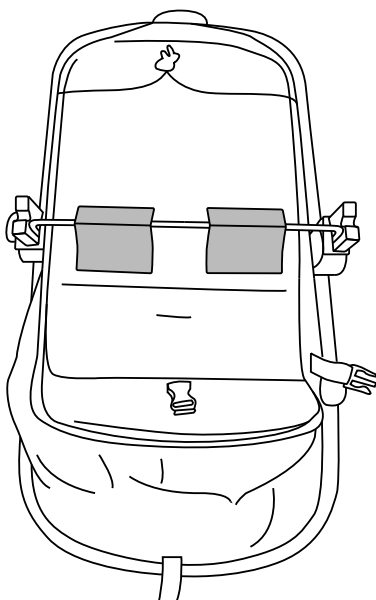

2 Attach bassinet to pushchair frame

Install the bassinet parent facing by aligning it with the frame and pushing it in the direction of the arrow. Ensure the seat clicks into place and is fully locked. If the harness system is attached to the seat then remove it by pushing through the plastics on the end pieces back through the seat back.

Remove harness

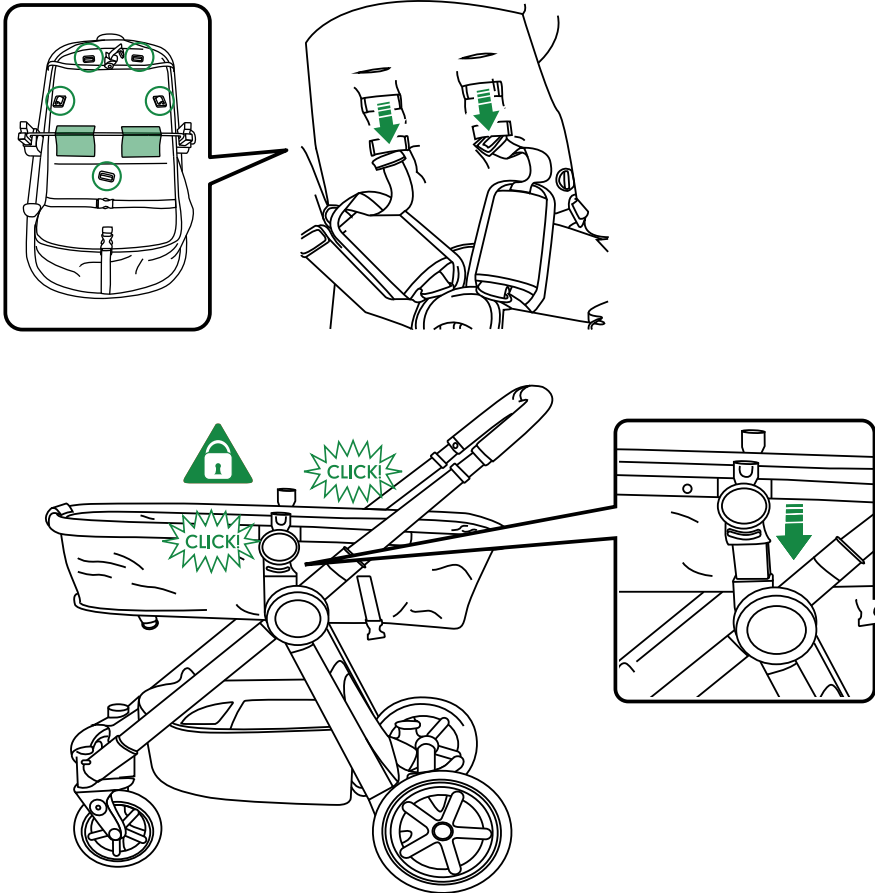

3 Insert bassinet liner

Take the bassinet insert (a) and place it inside the bassinet unit. Line up the zipper and zip runner (b) and zipper around the top of the bassinet to secure the bassinet liner in place (c).

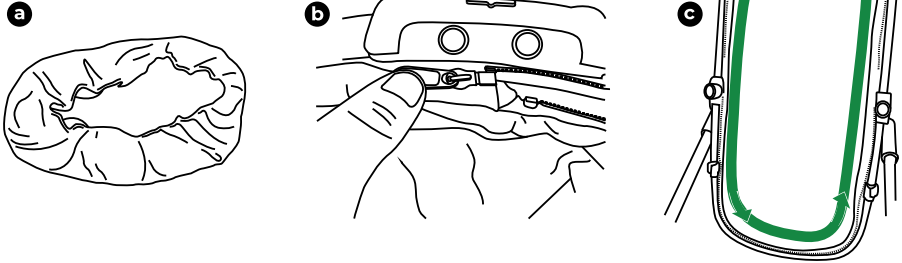

4 Attach the bumper bar

Insert the bumper bar on both sides of the bassinet unit as shown.

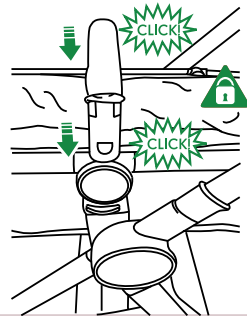

5 Attach the bassinet apron

Zipper on the bassinet apron all the way around the top of the bassinet. Fold the front flap of the apron over the bumper bar and secure down.

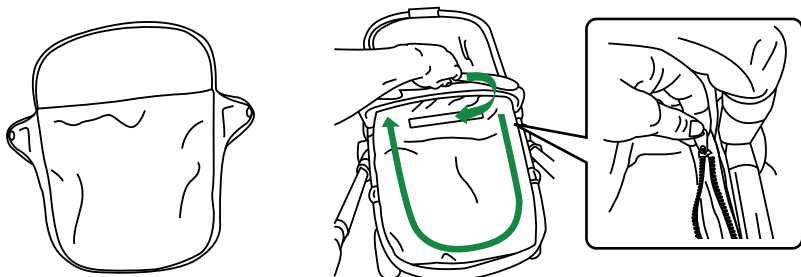

6 Attach the canopy

Position the canopy so that the rotating hinge mechanism on the canopy aligns with the connector joint on the bassinet frame. Insert the canopy hinge downward. Slide the hinge down into the frame connector.

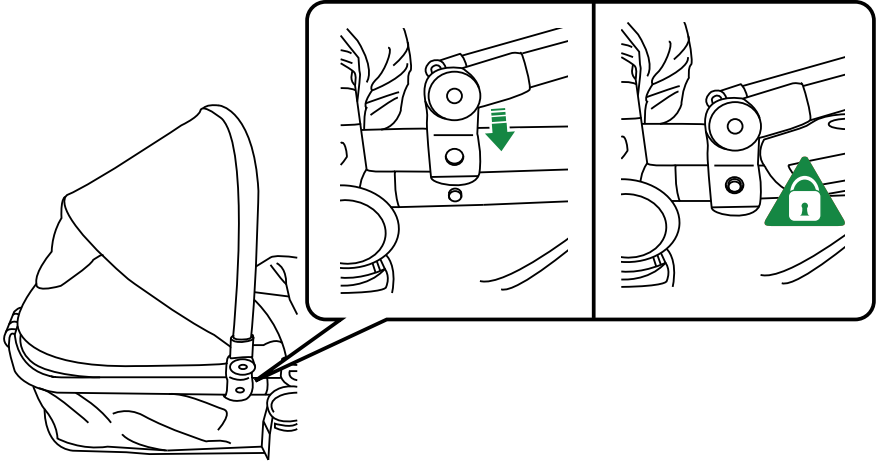

Locate the zipper on the inner edge of the canopy base and the corresponding zipper track along the rim of the bassinet frame. Feed the zipper tab into the slider until it clicks into place. Pull the zipper along the inside curve of the canopy, working from one side across to the other, as shown by the curved green arrow in the image. Ensure the zipper is closed all the way to prevent any gaps and to keep the canopy securely in place.

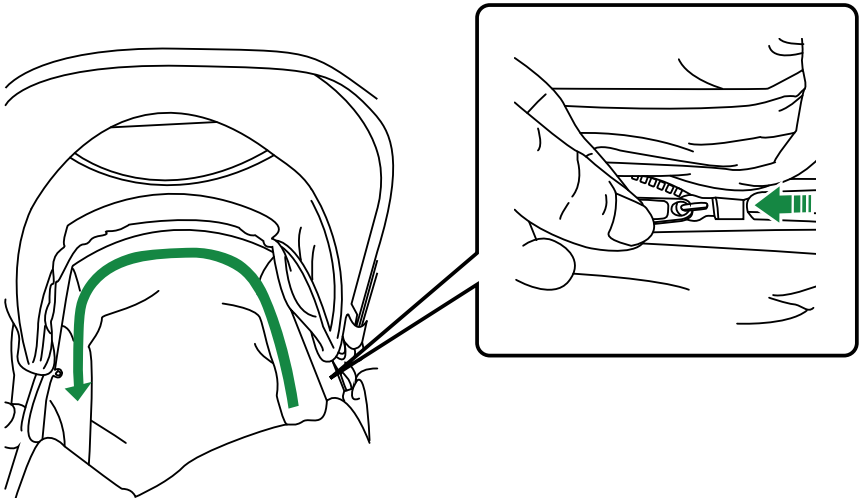

7 Setup complete

The bassinet should always be used parent facing as shown below.

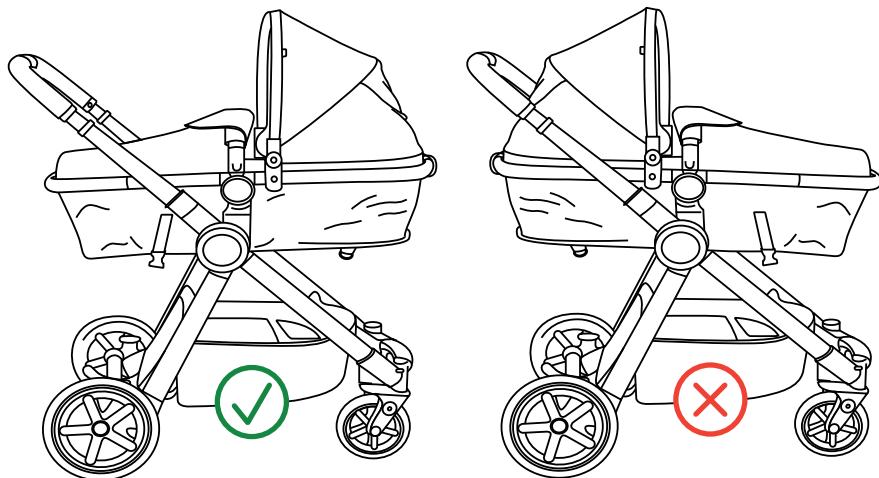

8 Bassinet removal

To remove the bassinet, lift the seat lock button and lift the bassinet unit upward to detach it.

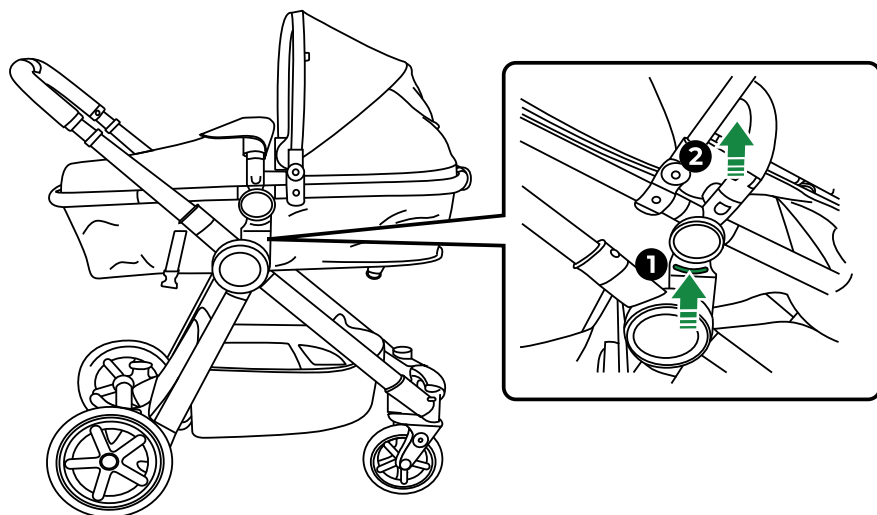

Seat assembly

1 Open up the seat unit

Open the seat in the direction of the arrow until you hear a "click."
Then check to ensure the seat is securely locked in place.

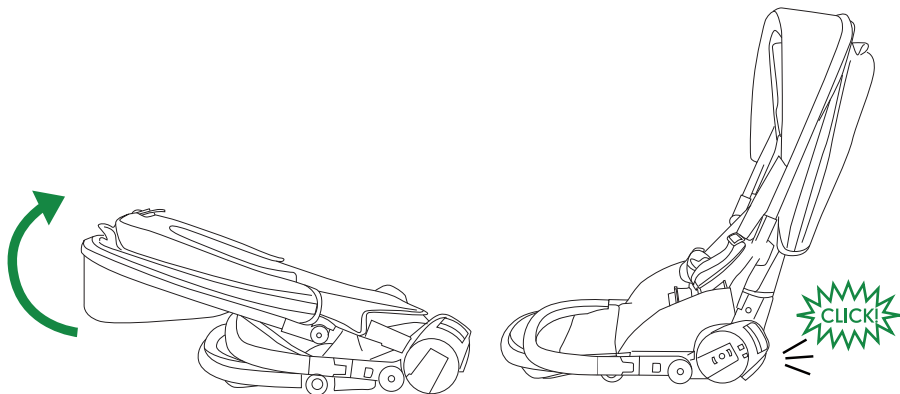

2

Open the front bumper bar in the direction of the arrow until it clicks,
and confirm that it is fully locked
in position.

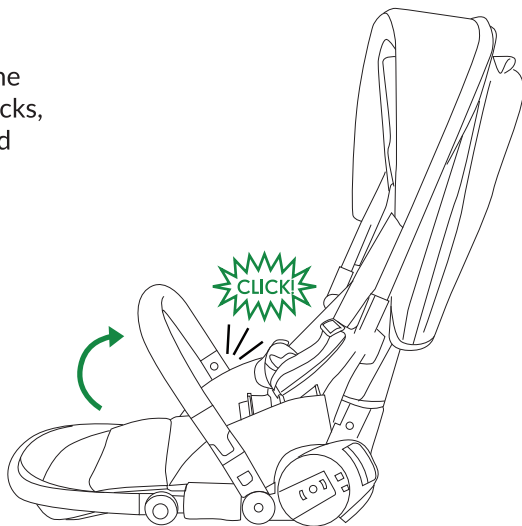

3

Connect the lower two straps to form the seat legrest.

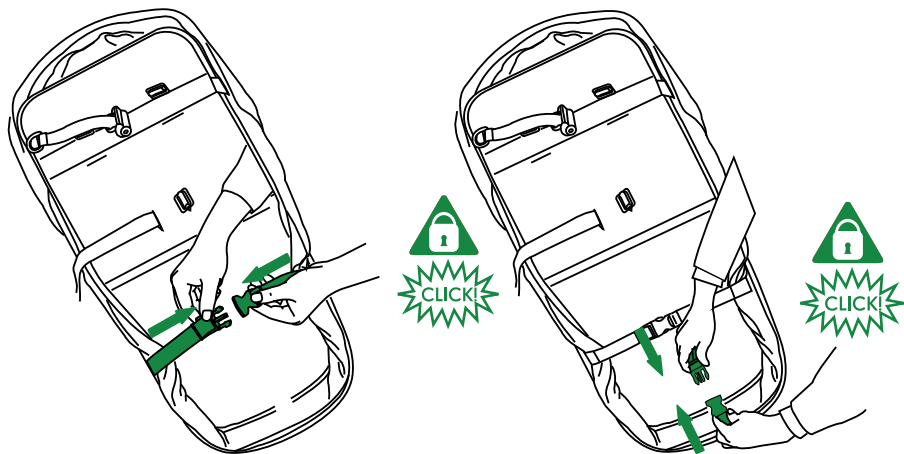

4

Take the harness and feed the plastic clip ends through the corresponding slits on the seat back.

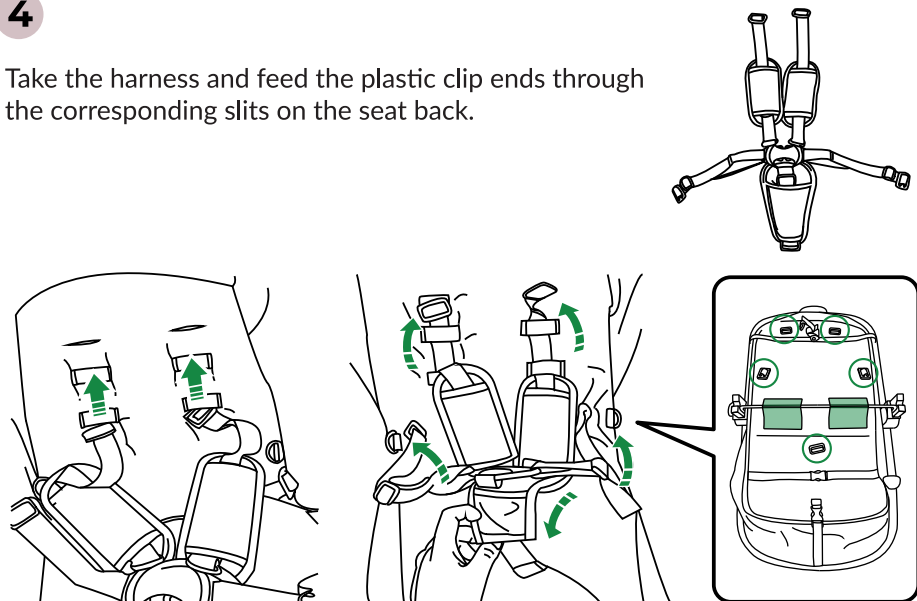

5

To tighten the seat back on the stroller: Pull both straps located at the back of the seat upward simultaneously (marked as step ①). While holding the straps, press the locking clasp upward to secure the adjustment (step ②).

This will draw the seat fabric tighter and keep the seat back more upright and supportive. Make sure both sides are evenly adjusted.

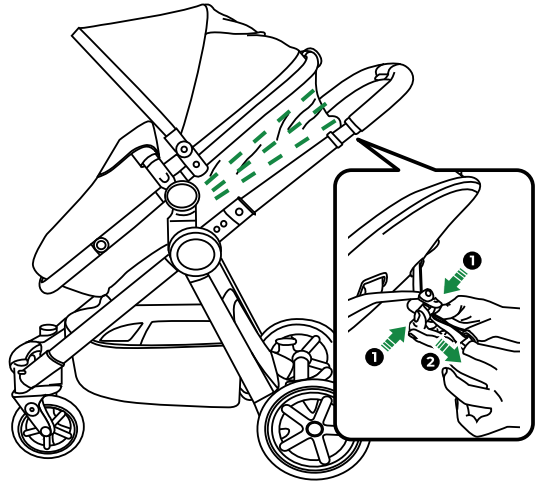

Forward & reverse seat installation/seat removal

1

Install the seat facing forward by aligning it with the frame and pushing it in the direction of the arrow. Ensure the seat clicks into place and is fully locked.

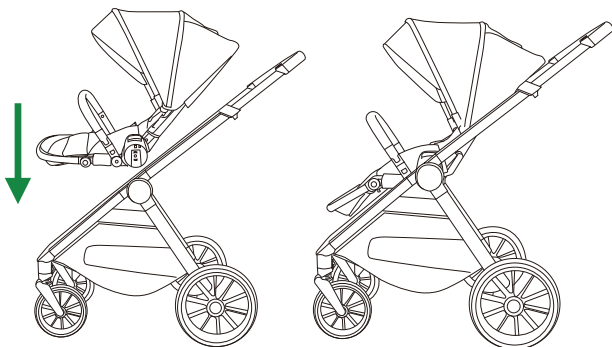

2

Install the seat in the rear-facing position. Align it with the frame and push in the direction of the arrow until it locks into place. Ensure the seat is securely locked.

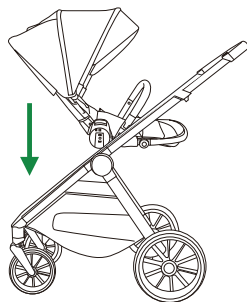

3

To remove the seat, lift the seat lock button and lift the seat upward to detach it.

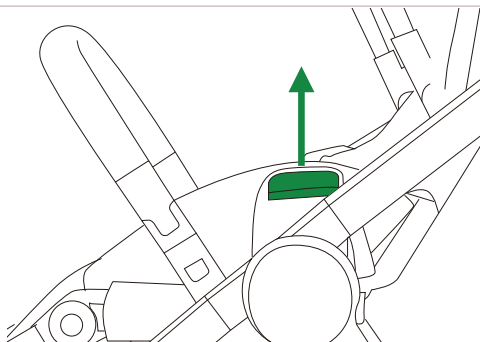

Install/remove/open the bumper bar

1

Insert the front bumper bar into the plastic slots on both sides of the seat until you hear a "click." Ensure it is securely locked in place.



2

Press the front bumper bar lock button and pull it out to remove the bumper bar.

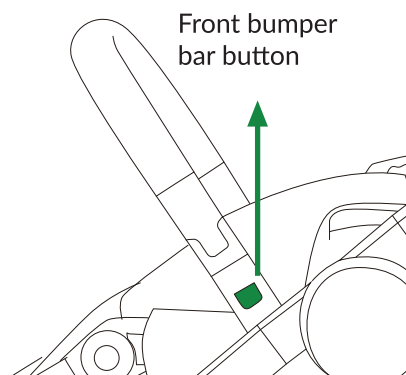

3

Press the lock button on the front bumper bar and pull out one side to open it.

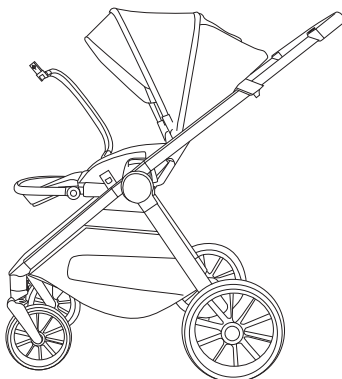

Telescopic handle adjustment

1

Squeeze the handle adjustment button inwards to raise or lower the handle to your desired height.

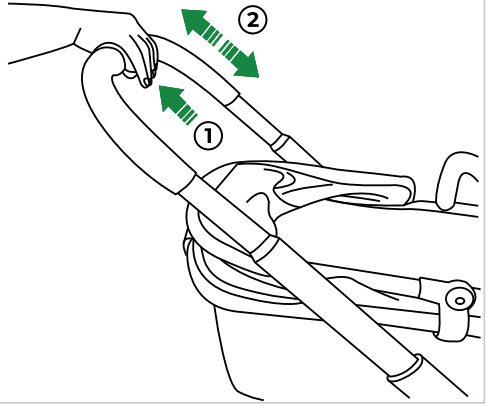

Leg rest adjustment

1

Press the buttons on each side of the leg rest to adjust the position of the leg rest up and down.

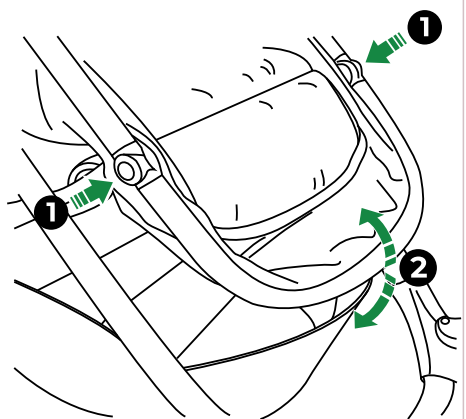

Seat back angle adjustment

1

Pull the backrest adjustment lever to change the angle of the seat backrest, moving it up or down as needed.

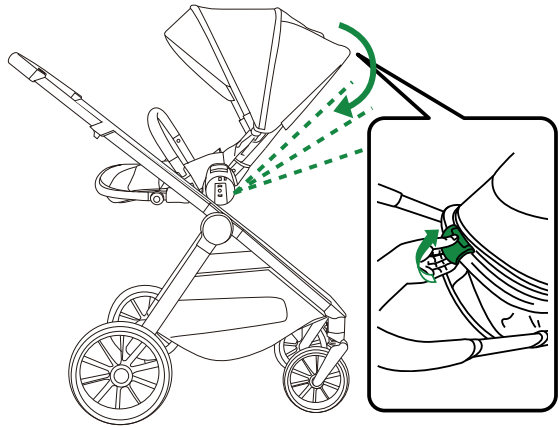

Canopy adjustment

1

Adjust the canopy position by pulling the canopy front bar backwards or forwards.

To extend the canopy more, you can undo the zipper and pull the canopy down further.

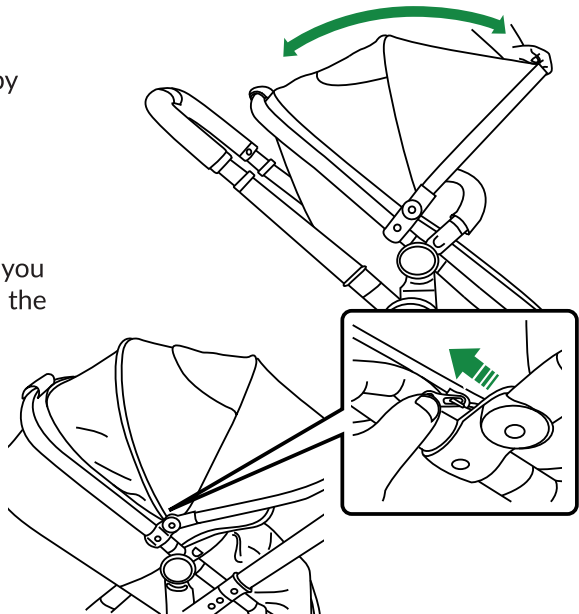

Brake operation

1

If the brake pedal is pressed down, the rear wheels are locked and the stroller cannot move. When the pedal is lifted up, the stroller can move freely.

Warning: Always engage the brake when placing your child in or taking them out of the stroller to ensure their safety.

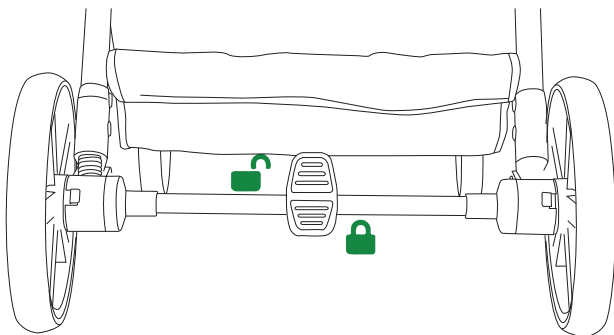

Fitting the rain cover

1

The rain cover can be used in both bassinet and pushchair mode.

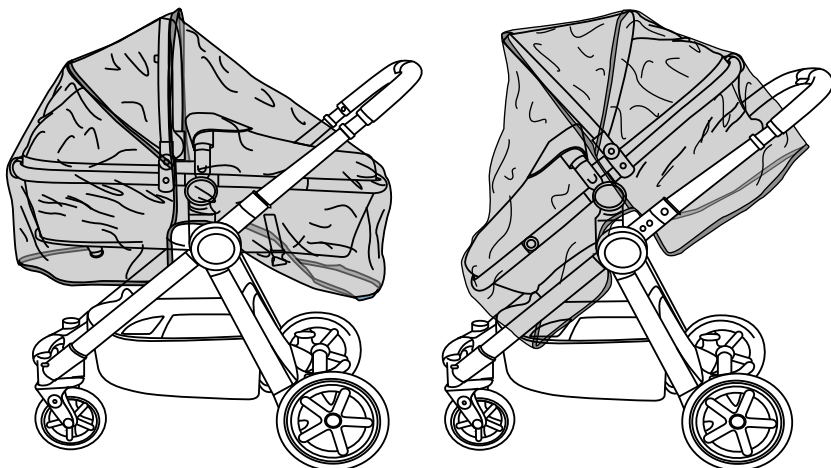

Safety belt usage

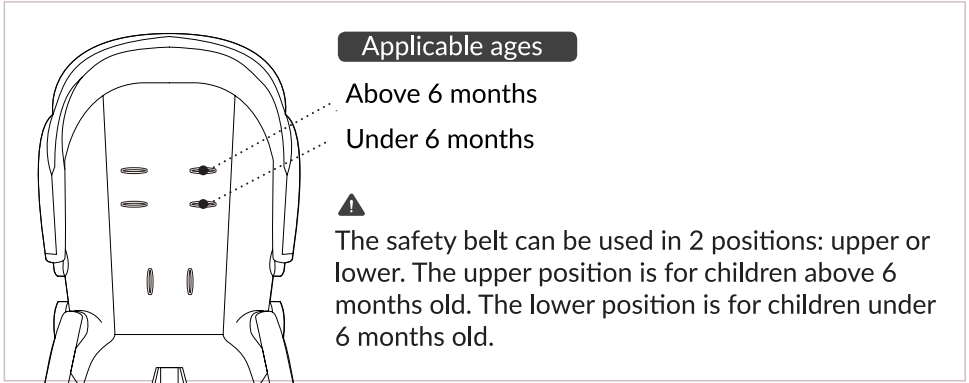

- 1** Insert part b1 into part a1, insert part b2 into part a2, a "click" will indicate that they are attached correctly.

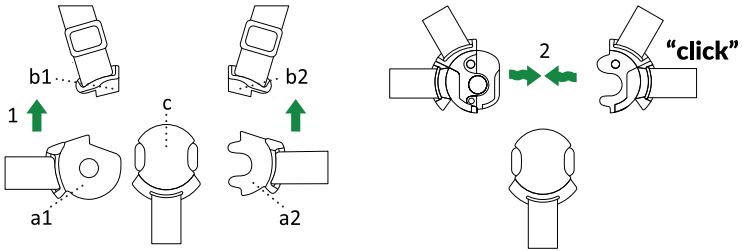

- 2** Place part a2 on top of part a1, place the buckle component "c", as shown in the image above on top of the combined parts a1+a2. A click will indicate they are attached correctly

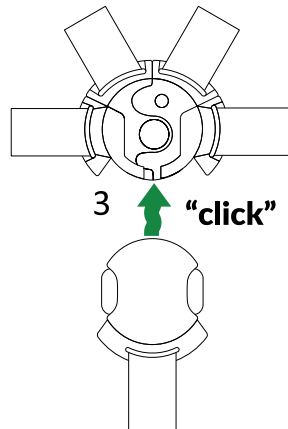

3 To release the buckle, press the buttons on either side.



Folding the pushchair

1

1. Recline the Seat Forward

As shown in Figure a, pull the backrest adjustment lever to rotate the seatback forward, so it folds over the seat (Figure b).

2. Lower the Handlebar & Prepare to Fold

As shown in Figure c, adjust the handlebar to its lowest height setting. Then, pull the buttons on either side of the frame d, and lower the handlebar downwards until it is all the way down e.

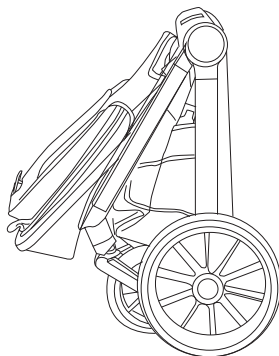
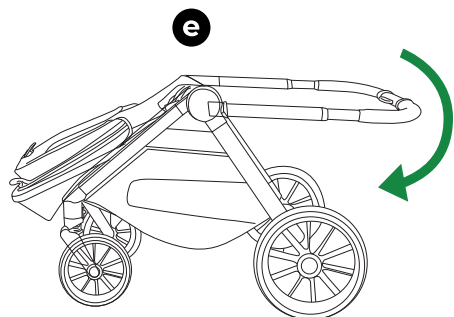
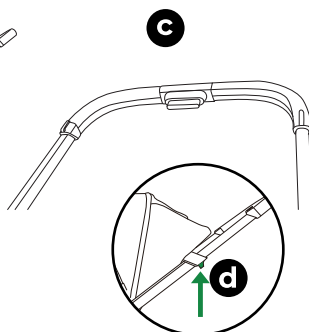
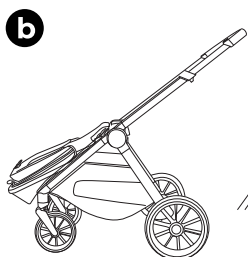
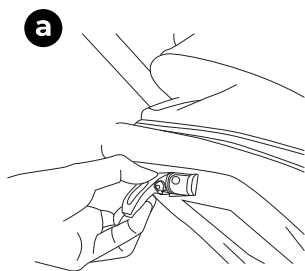

Car seat adapters

1 Attach adapters to the infant carrier

Click the car seat adapters into the corresponding side on the infant carrier.

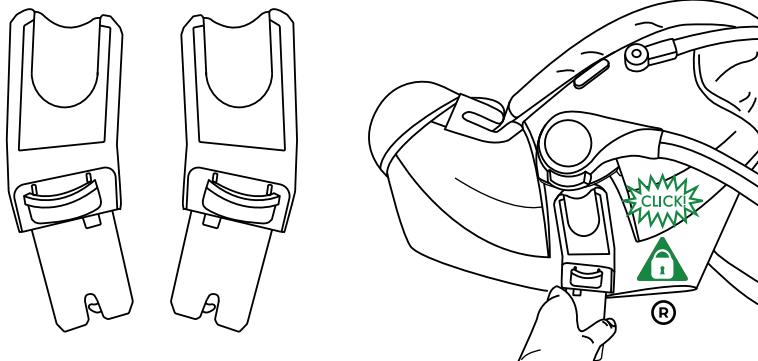

2 Attach infant carrier to the frame

Align the infant carrier over the pushchair frame in the parent facing position and lower it onto the frame. Ensure both sides are clicked in securely. Check they are secure before progressing.

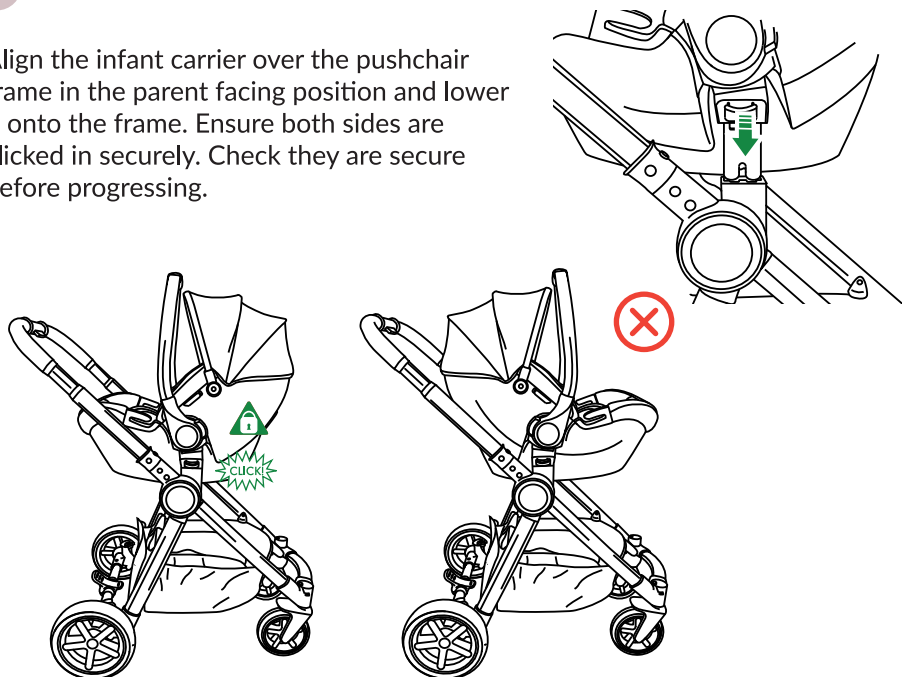

3 Remove infant carrier from frame

Lift the release buttons either side and lift the infant carrier off the frame.

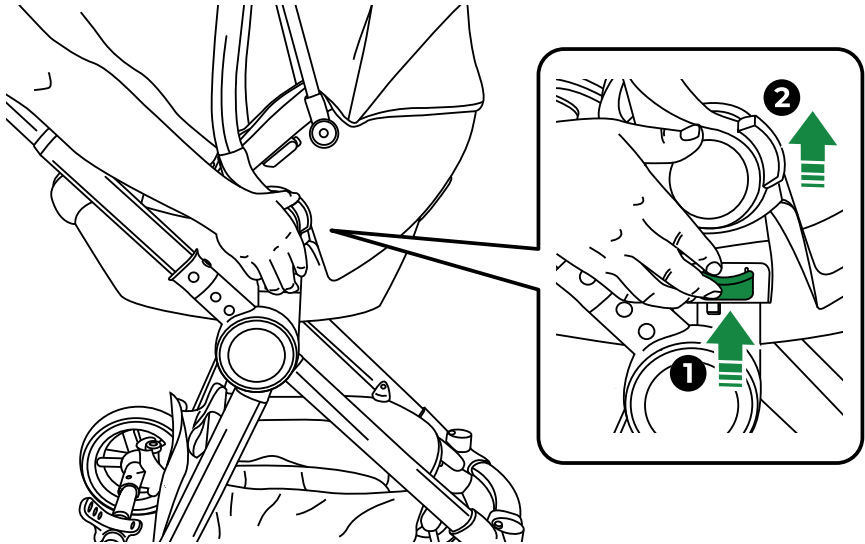

4 Remove adapters from infant carrier

Push the adapter release buttons (1) on both top sides of the infant carrier to release the adapters.

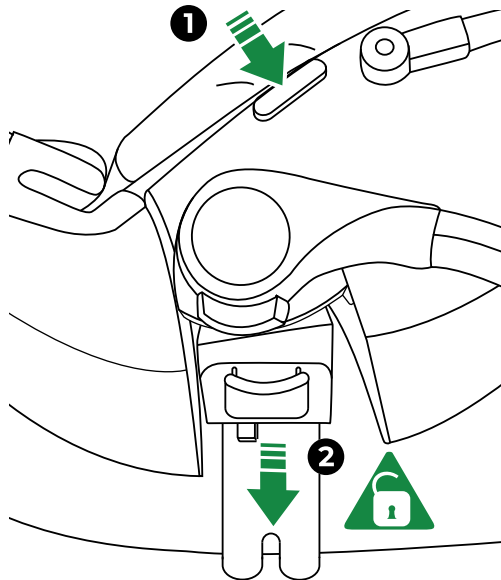

Care and maintenance

- Please check on a regular basis that the brakes, wheels, latches, connecting elements, belt systems and seams are properly functional.
- Do not expose the stroller to strong sunshine.
- Sponge clean only.
- After use in rain or snow, the wheels should be lubricated and the stroller dried to prevent rust.
- Care for, clean and check this stroller regularly.
- Do not use accessories that have not been approved by the manufacturer.

Your child's safety is your responsibility

If you have a problem with this product or require replacement parts, please visit www.mybabiie.com/support

Register your product at: www.mybabiie.com/warranties

Pushchair Do's & Don'ts



Do use your brakes!

Ensure the parking brake is engaged during the loading and unloading of children & when the pushchair is stationary.

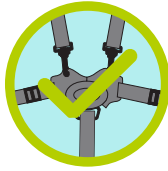

Do always use the restraint system!

Ensure that the child restraint system is correctly fitted at all times.



Do keep your pushchair clean and dirt free.

Use a clean white cloth, warm water and a mild detergent to keep your pushchair clean.



Do always keep two hands on the handles when pushing.

You could lose control of your pushchair if not steering with both hands.



Do follow manufacturers instructions when assembling and using your pushchair.

For safety, please refer to our instruction manuals or contact customer support if you're unsure.



Don't use your pushchair up and down stairs!

Don't use your pushchair up or down stairs or to bump kerbs.



Don't hang bags off the handles!

Bags and other items should not be hung from the handles as this can affect the stability of the pushchair.



Don't run or skate with your pushchair!

Our products are not suitable for running or skating.



Don't carry the stroller with baby inside!

Our pushchairs are not designed to be carried with your baby inside them.



Don't put hot drinks in the cup holder.

Hot drinks burn and can easily spill from the bottle holder.



Don't jetwash your pushchair.

Some jet washers are very powerful and could damage parts of your pushchair!



Don't leave your child un-attended in their pushchair.

Always keep your child and pushchair in view to avoid accidents.



Don't treat your pushchair like a trolley.

Don't load your pushchair up with all your shopping as they are not built for this purpose and could cause damage.



Don't use your pushchair as a bumper cart!

Damage can easily occur if your pushchair is knocked into other things.



Don't smoke around your pushchair.

We wouldn't want your pushchair or little one getting hurt or damaged!



Don't leave your pushchair unattended on extreme gradients.

Even with your brakes on your pushchair is at risk from tipping or sliding on extreme gradients!



Don't sit in the pushchair unless the user is under the guideline weight.

Our pushchairs are designed to hold a maximum weight. If exceeded this will cause damage!



Do enjoy your My Babie product!

Go out and have fun adventures with your little one!

Notas de seguridad y cuidado

IMPORTANTE - LEA CUIDADOSAMENTE Y GUARDE ESTAS INSTRUCCIONES PARA FUTURAS CONSULTAS

Retire todo el embalaje y las etiquetas no permanentes y deséchelos de manera segura antes de usar este producto. La seguridad de su hijo podría correr peligro si no sigue estas instrucciones. Este cochecito está diseñado para 1 niño desde 0 meses hasta un peso de 22 kg.

ADVERTENCIA: Nunca deje al niño desatendido.

ADVERTENCIA: La carga desigual o excesiva de artículos sobre o dentro de la carriola puede hacer que el producto se vuelque y cause lesiones.

ADVERTENCIA: El peso máximo previsto dentro de la cesta de la compra es de 3 kg.

ADVERTENCIA: Asegúrese de que todos los dispositivos de bloqueo estén activados antes de su uso.

ADVERTENCIA: Para evitar lesiones, asegúrese de que el niño se mantenga alejado al desplegar y plegar este cochecito.

ADVERTENCIA: No permita que el niño juegue con este producto.

ADVERTENCIA: Utilice siempre el sistema de retención.

ADVERTENCIA: Verifique que el cuerpo del cochecito esté correctamente acoplado antes de su uso.

ADVERTENCIA: No coloque bebidas o líquidos calientes en el portavasos.

ADVERTENCIA: Este producto no es apto para correr o patinar.

ADVERTENCIA: No inserte colchones adicionales en la carriola.

ADVERTENCIA: No se deben utilizar accesorios que no estén aprobados por el fabricante.

ADVERTENCIA: ¡Este cochecito ha sido diseñado para un niño y debe usarse para el transporte de un solo niño!

ADVERTENCIA: Utilice siempre la correa de la entrepierna en combinación con el cinturón.

ADVERTENCIA: Este cochecito no reemplaza una cuna o una cama. Si su hijo necesita dormir, debe colocarlo en una cuna o cama adecuada.

ADVERTENCIA: Solo se deben utilizar piezas de repuesto suministradas o recomendadas por My Babiie.

ADVERTENCIA: Cualquier carga adherida a la manija y en la parte posterior del respaldo y en los costados de la carriola afectará la estabilidad de la carriola.

ADVERTENCIA: El dispositivo de estacionamiento debe estar activado al colocar y retirar a los niños.

EN 1888-1:2018+A1:2022 y EN 1888-2:2018+A1:2022 aprobado

Cuidado y mantenimiento

- Compruebe periódicamente que los frenos, las ruedas, los pestillos, los elementos de conexión, el cinturón
los sistemas y las costuras funcionan correctamente.
- No exponga el cochecito a la luz solar intensa.
- Solo limpie con esponja.
- Después de su uso bajo la lluvia o la nieve, se deben lubricar las ruedas y secar la carriola para evitar la oxidación.
- Cuide, limpie y revise este cochecito regularmente.

La seguridad de tu hijo es tu responsabilidad

Si tiene un problema con este producto o necesita piezas de repuesto, visite www.mybabiie.com/support

Registre su producto en: www.mybabiie.com/warranties

Piezas del cochecito

Marco de cochecito

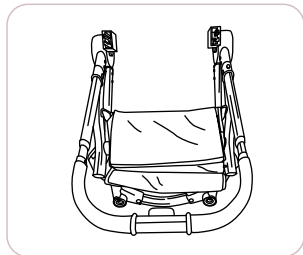

Capota para cochecito

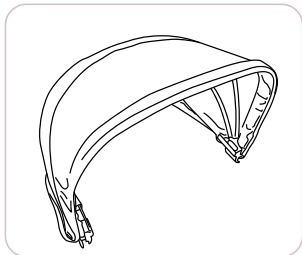

Barra de parachoques

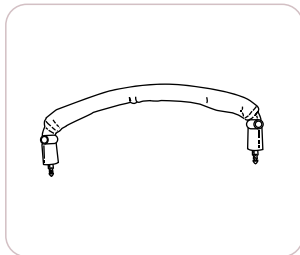

Rueda delantera (x2)



Rueda trasera (x2)

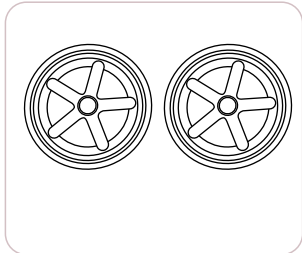

Unidad de asiento



Inserto de cuna



Saco de pies

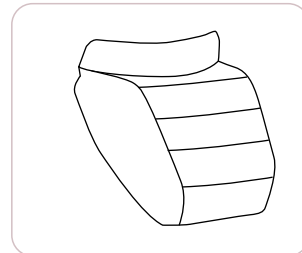

Arnés para cochecito

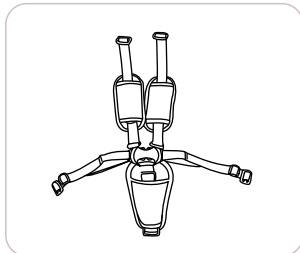

Funda de cuna

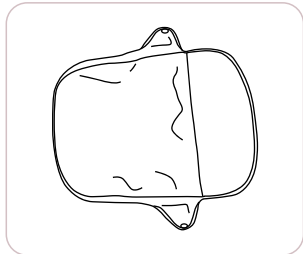

Protector de lluvia

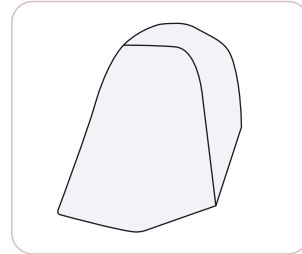

Adaptadores para asientos de coche

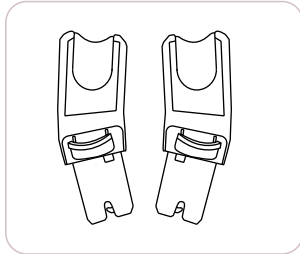

Abrir el marco

Abra el marco en la dirección de la flecha (como se muestra en las Figuras 1 y 2) hasta que oiga un clic (Figura 3). A continuación, asegúrese de que el marco esté completamente bloqueado.

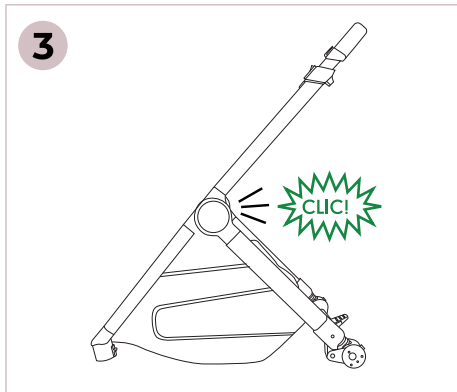
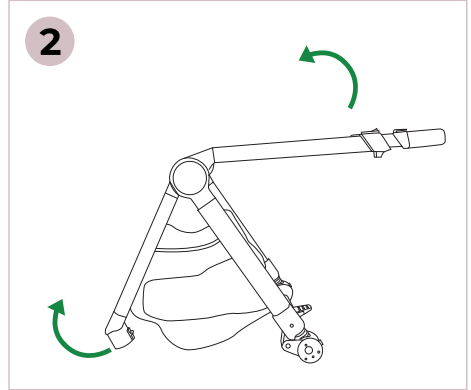
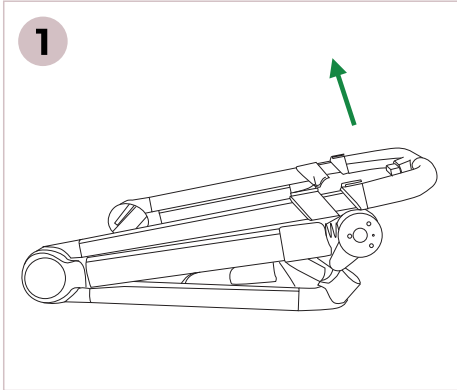

Instalar/quitar las ruedas delanteras

1

Alinee la abertura de plástico del soporte de montaje de la rueda delantera con la rueda e insértela hasta que encaje en su lugar y quede firmemente bloqueada. Repita los mismos pasos con la otra rueda delantera.

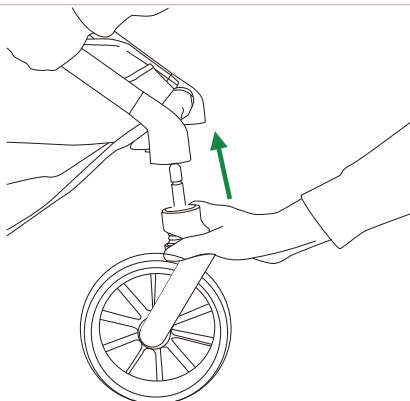

2

Al deslizar el bloqueo de orientación de la rueda delantera hacia abajo, la rueda queda fija y no puede girar. Deslícelo hacia arriba para permitir una rotación de 360 grados.

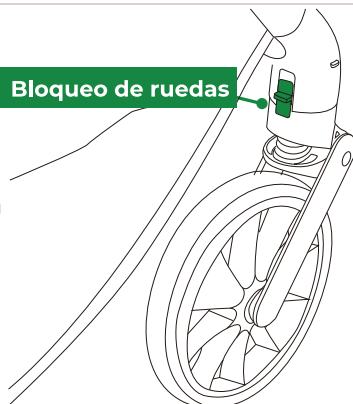

3

Para retirar la rueda delantera, presione la pequeña placa metálica y tire suavemente de ella con la mano. Repita el procedimiento con la otra rueda delantera.

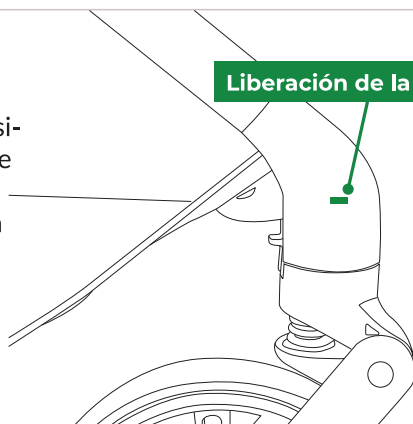

Instalar/quitar las ruedas traseras

1

Alinee el orificio de plástico en el soporte de la rueda trasera e inserte la rueda hasta que encaje firmemente. Repita este proceso con la otra rueda trasera.

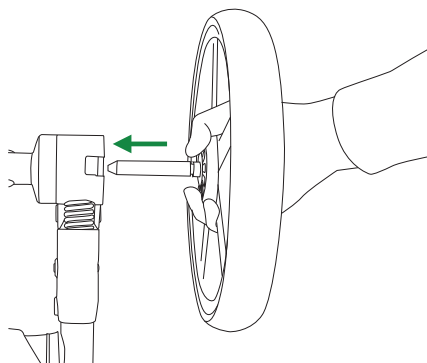

2

Para retirar la rueda trasera, presione la placa metálica de bloqueo y tire de ella. Retire la otra rueda trasera de la misma manera.

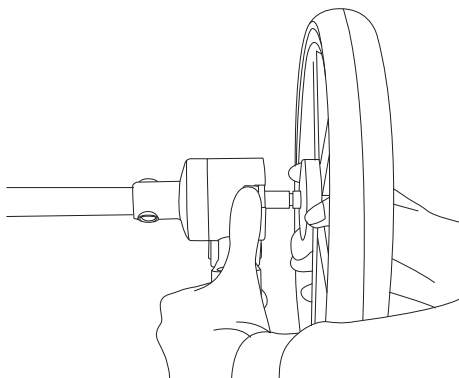

Montaje del moisés

1 Preparar el moisés

Coloque las correas de velcro alrededor de la barra de metal para asegurarla a la base del moisés.

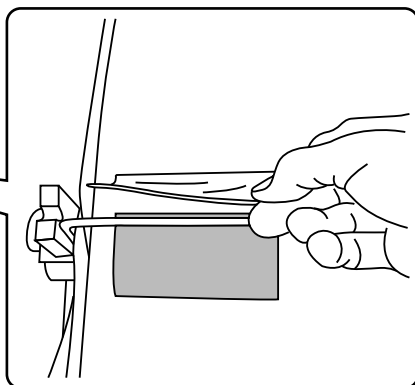
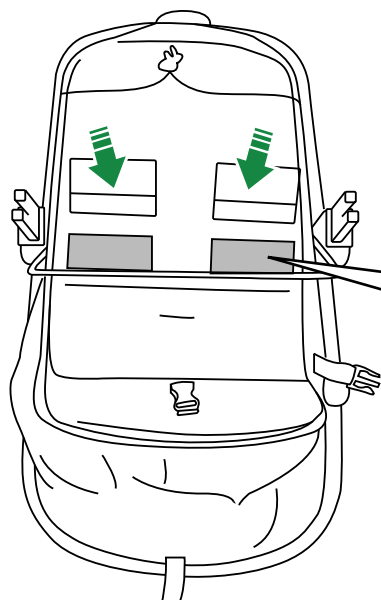

Base segura

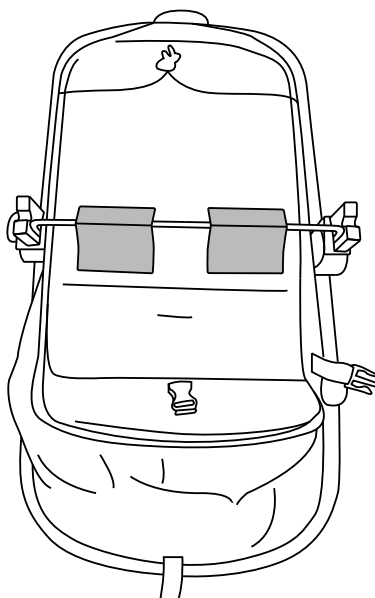

2 Fije el moisés al marco del cochecito

Instale el moisés mirando hacia los padres alineándolo con el armazón y empujándolo en la dirección de la flecha. Asegúrese de que el asiento encaje en su lugar y esté completamente bloqueado. Si el sistema de arnés está fijado al asiento, retírelo empujando los plásticos de los extremos hacia atrás a través del respaldo.

Quitar el arnés

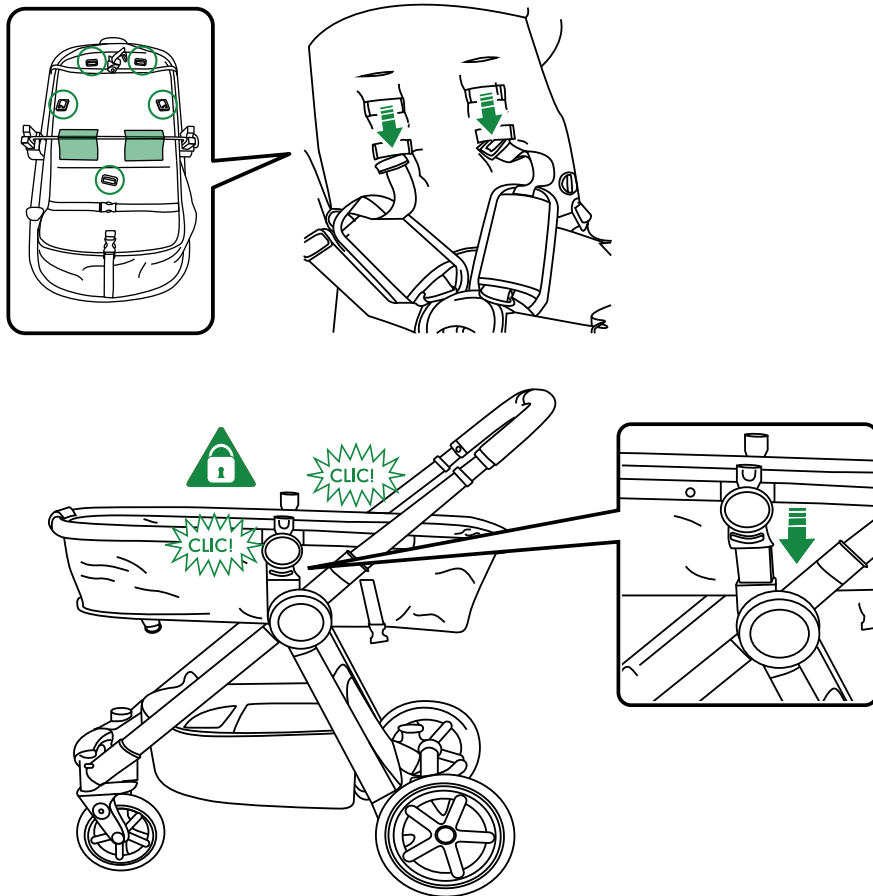

3 Insertar el forro del moisés

Tome el inserto del moisés (a) y colóquelo dentro de la unidad. Alinee la cremallera y su guía (b) con la cremallera alrededor de la parte superior del moisés para asegurar el forro en su lugar (c).

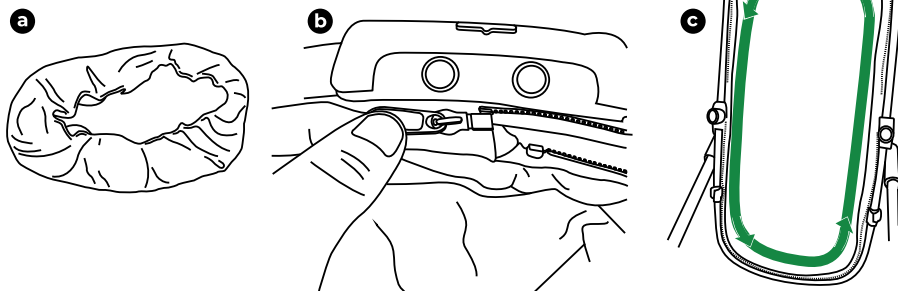

4 Coloque la barra de parachoques

Inserte la barra protectora en ambos lados de la unidad del moisés como se muestra.

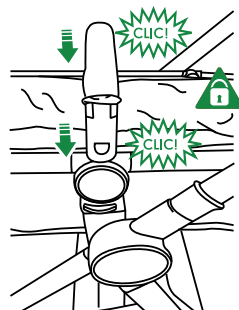

5 Coloque el delantal del moisés

Cierre la cremallera del faldón del moisés hasta el borde superior. Doble la solapa frontal del faldón sobre la barra de seguridad y asegúrela.

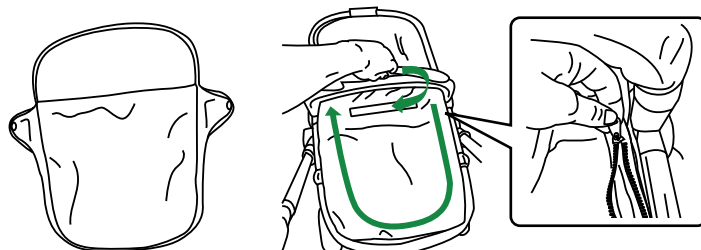

6 Coloque el dosel

Coloque la capota de modo que el mecanismo de bisagra giratoria se alinee con la unión del marco del moisés. Inserte la bisagra de la capota hacia abajo. Deslice la bisagra hacia abajo en el conector del marco.

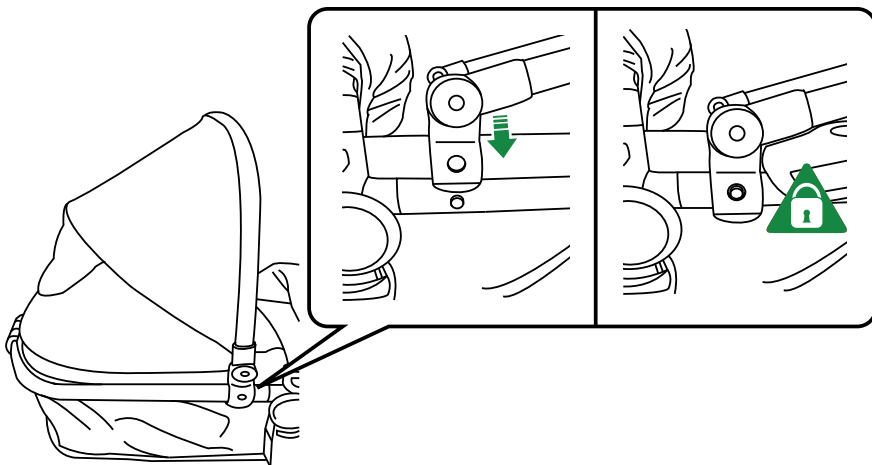

Localice la cremallera en el borde interior de la base de la capota y el riel correspondiente a lo largo del borde del marco del moisés. Introduzca la pestaña de la cremallera en el deslizador hasta que encaje. Tire de la cremallera a lo largo de la curva interior de la capota, de un lado a otro, como lo muestra la flecha verde curva en la imagen. Asegúrese de que la cremallera esté completamente cerrada para evitar huecos y mantener la capota firmemente en su lugar.

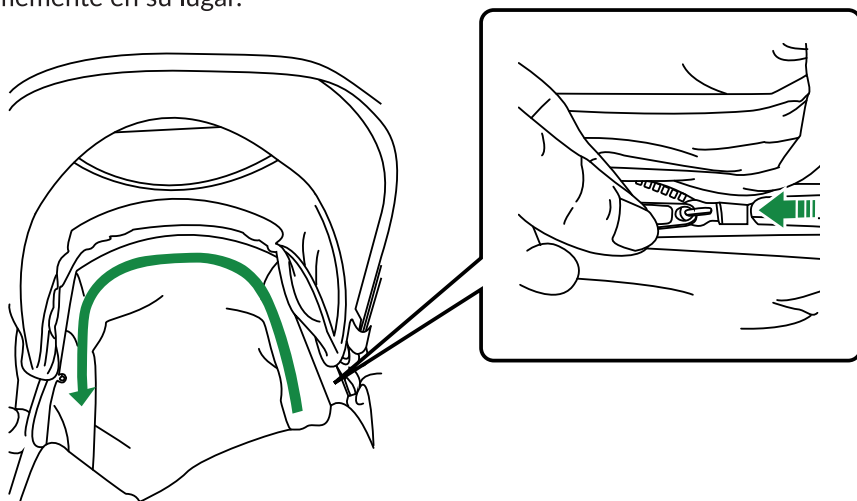

7 Configuración completada

El moisés debe utilizarse siempre mirando hacia los padres, como se muestra a continuación.

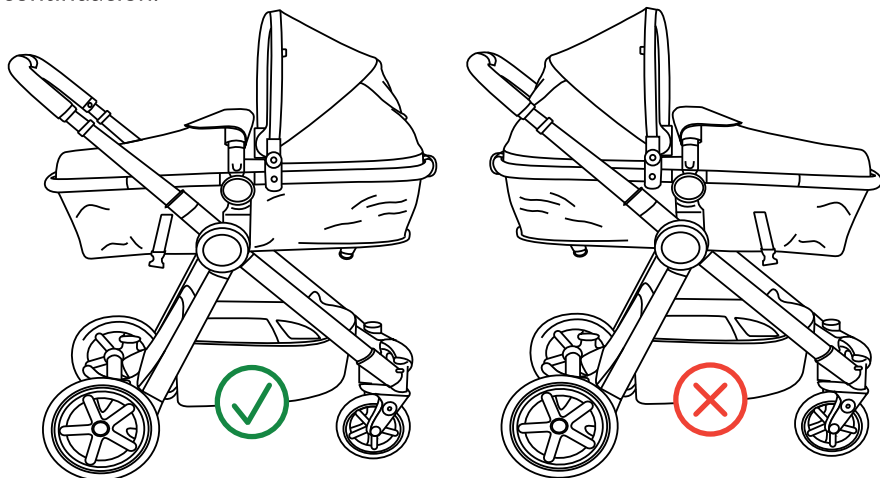

8 Retirada del moisés

Para quitar el moisés, levante el botón de bloqueo del asiento y levante la unidad del moisés hacia arriba para separarla.

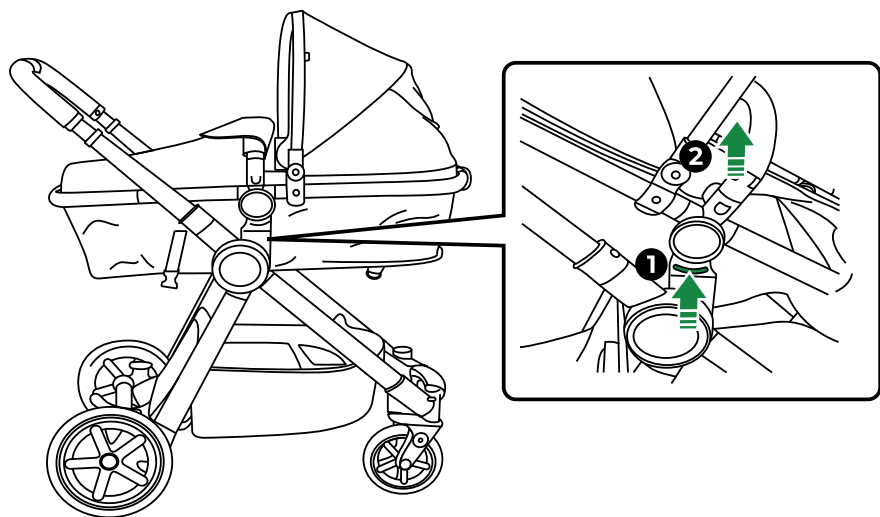

Conjunto de asiento

1 Abra la unidad del asiento

Abra el asiento en la dirección de la flecha hasta oír un clic.
A continuación, compruebe que el asiento esté bien fijado.

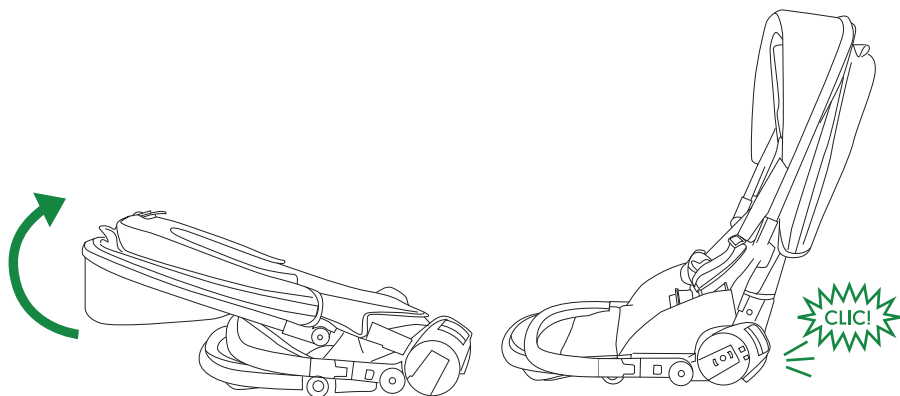

2

Abra la barra del parachoques delantero en la dirección de la flecha hasta que haga clic y confirme que esté completamente bloqueada en su posición.

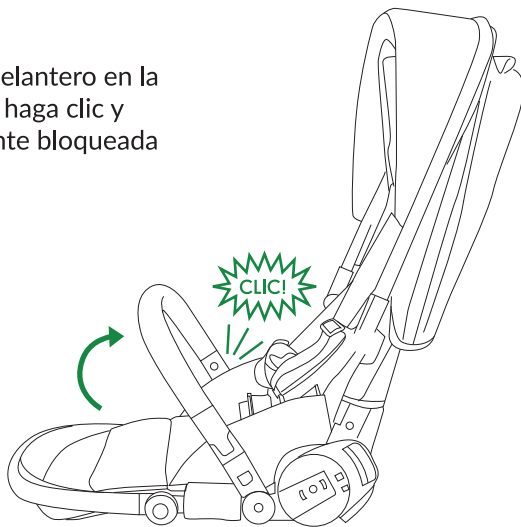

3

Conecte las dos correas inferiores para formar el reposapiernas del asiento.

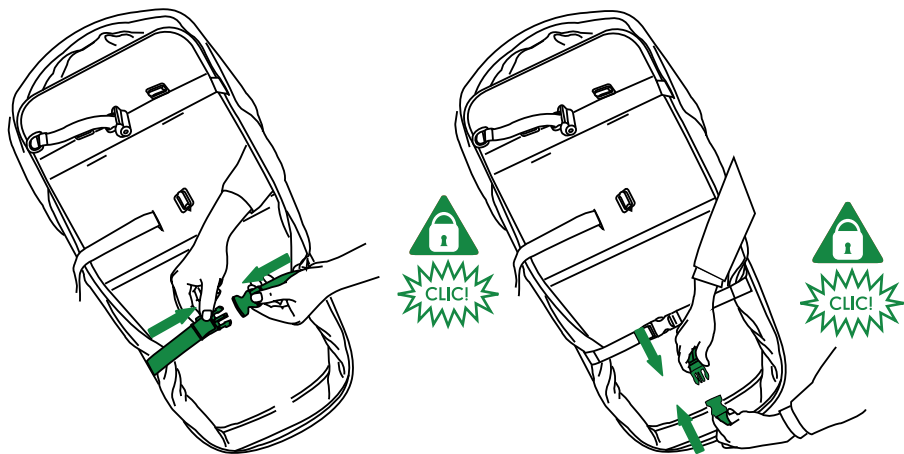

4

Tome el arnés y pase los extremos del clip de plástico a través de las ranuras correspondientes en el respaldo del asiento.

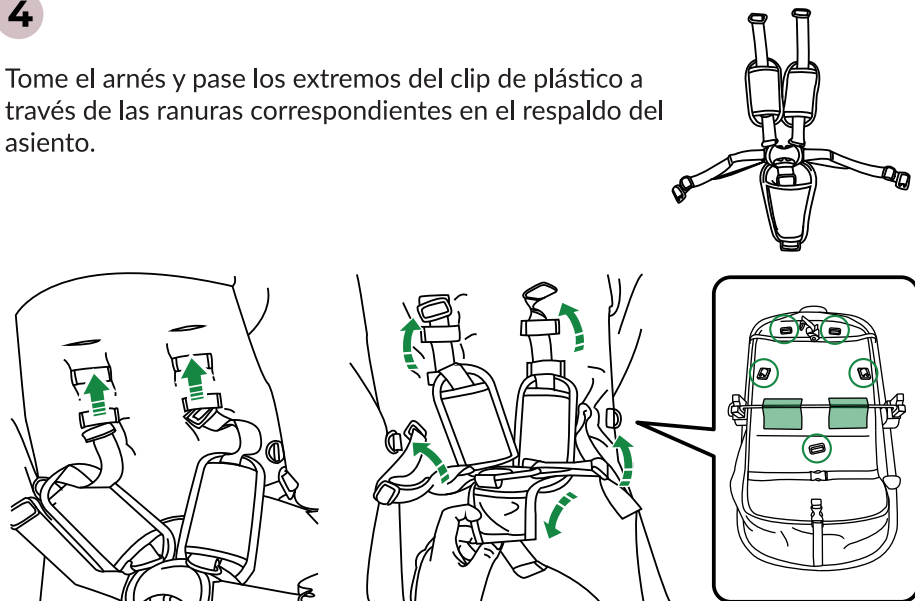

5

Para ajustar el respaldo del cochecito: Tire simultáneamente de ambas correas ubicadas en la parte trasera del asiento hacia arriba (paso 1). Mientras sujeta las correas, presione el cierre de seguridad hacia arriba para asegurar el ajuste (paso 2).

Esto tensará la tela del asiento y mantendrá el respaldo más erguido y con mejor soporte. Asegúrese de que ambos lados estén ajustados uniformemente.

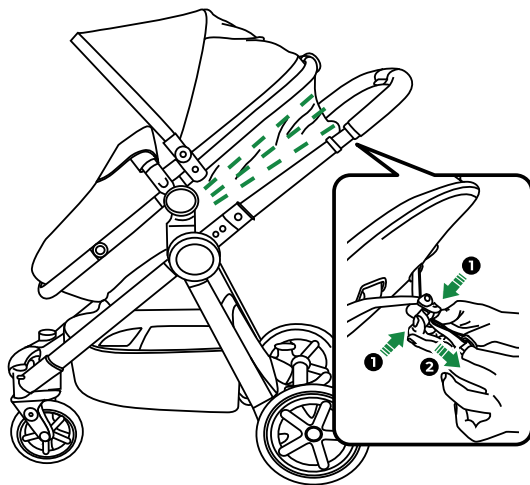

Instalación y extracción del asiento hacia adelante y hacia atrás

1

Instale el asiento mirando hacia adelante alineándolo con el armazón y empujándolo en la dirección de la flecha. Asegúrese de que el asiento encaje en su lugar y esté completamente bloqueado.

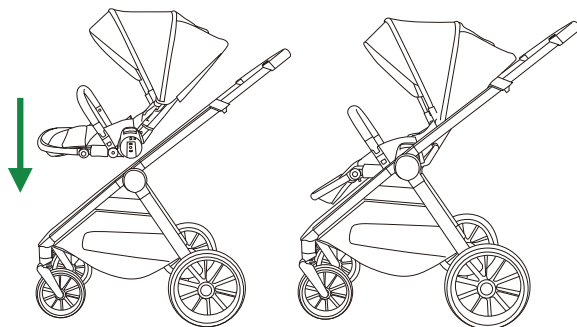

2

Instale el asiento en la posición orientada hacia atrás. Alinéelo con el chasis y empuje en la dirección de la flecha hasta que encaje. Asegúrese de que el asiento esté bien bloqueado.

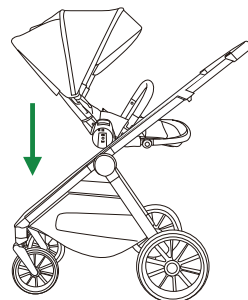

3

Para quitar el asiento, levante el botón de bloqueo del asiento y levante el asiento para soltarlo.

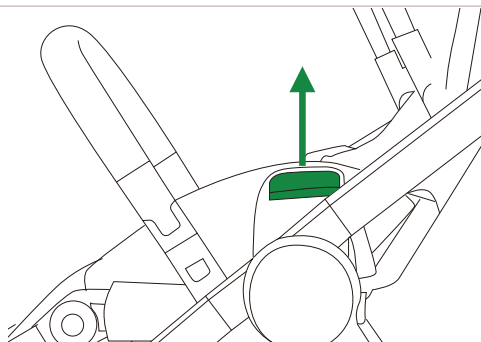

Instalar/quitar/abrir la barra de parachoques

1

Inserte la barra del parachoques delantero en las ranuras de plástico a ambos lados del asiento hasta que oiga un clic. Asegúrese de que esté bien fijada.

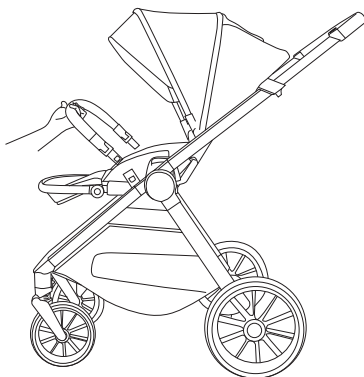

2

Presione el botón de bloqueo de la barra del parachoques delantero y tire de él para quitar la barra del parachoques.

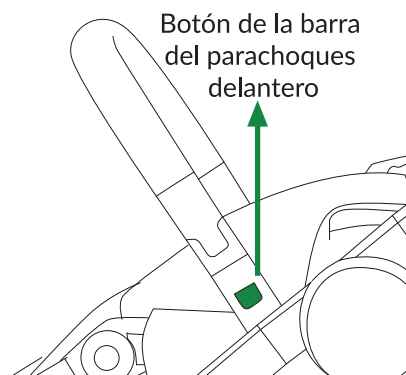

3

Presione el botón de bloqueo en la barra del parachoques delantero y tire de un lado para abrirlo.

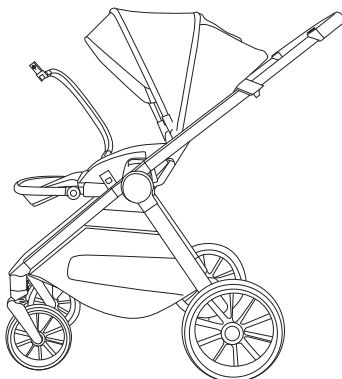

Ajuste del mango telescópico

1

Apriete el botón de ajuste del mango hacia adentro para subir o bajar el mango a la altura deseada.

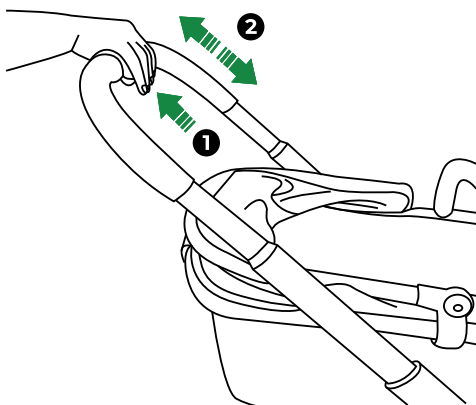

Ajuste del reposapiernas

1

Presione los botones a cada lado del reposapiernas para ajustar la posición del reposapiernas hacia arriba y hacia abajo.

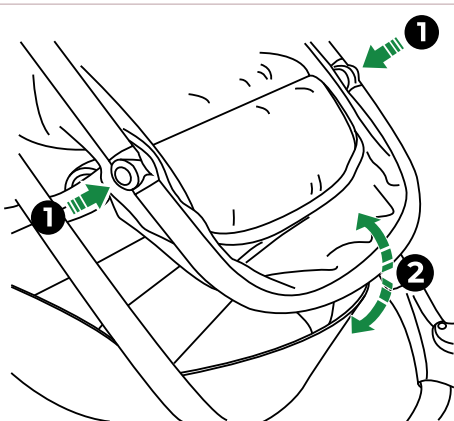

Ajuste del ángulo del respaldo del asiento

1

Tire de la palanca de ajuste del respaldo para cambiar el ángulo del respaldo del asiento, moviéndolo hacia arriba o hacia abajo según sea necesario.

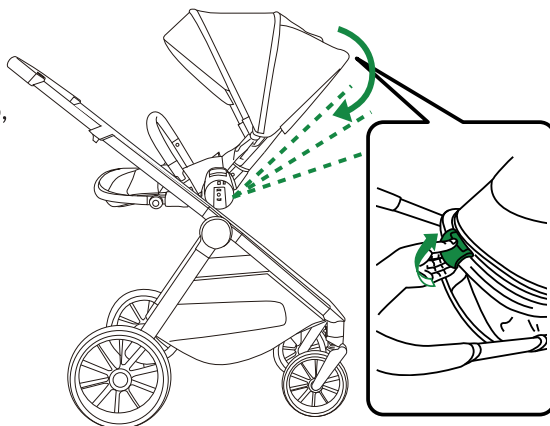

Ajuste del dosel

1

Ajuste la posición del toldo tirando de la barra frontal del toldo hacia atrás o hacia adelante.

Para extender más el toldo, puedes abrir la cremallera y tirar del toldo hacia abajo aún más.

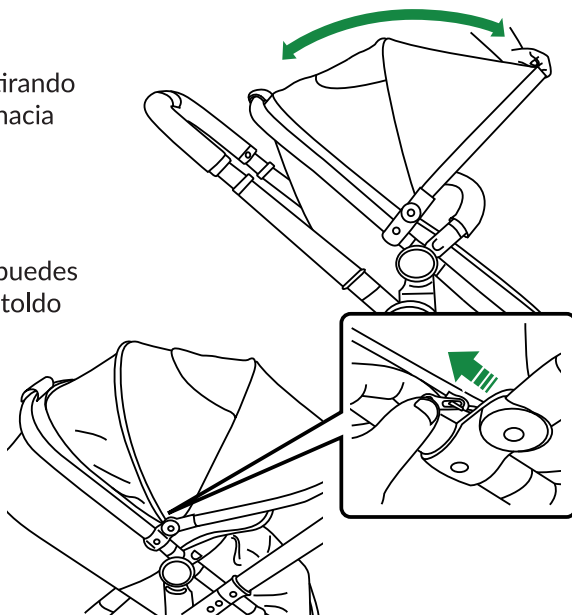

Funcionamiento del freno

1

Si se pisa el pedal del freno, las ruedas traseras se bloquean y la carriola no puede moverse. Al levantar el pedal, la carriola puede moverse libremente. Advertencia: Para garantizar su seguridad, accione siempre el freno al colocar o sacar a su hijo de la carriola.

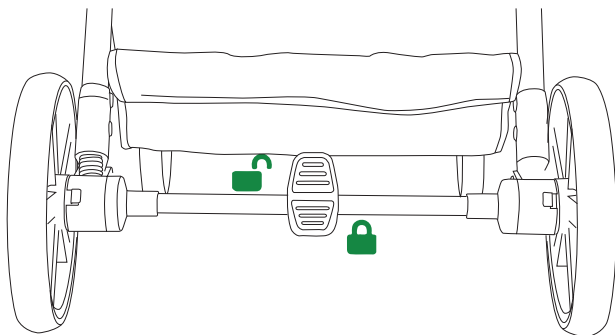

Instalación de la funda para la lluvia

1

La funda para lluvia se puede utilizar tanto en modo capazo como en modo cochecito.

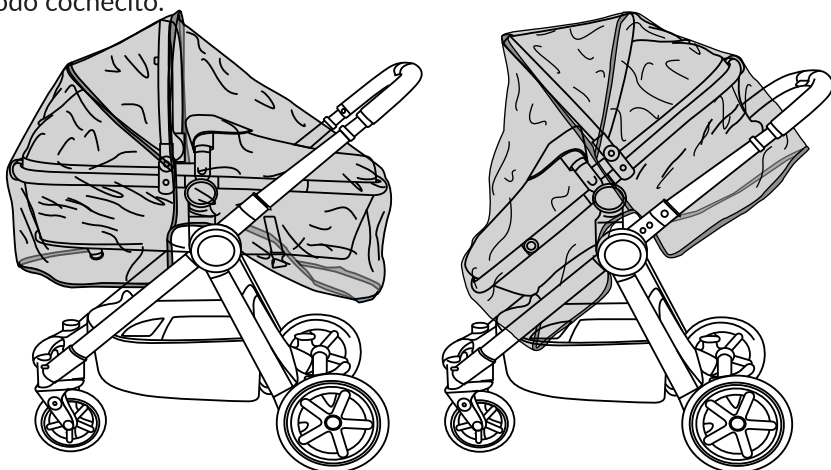

Uso del cinturón de seguridad

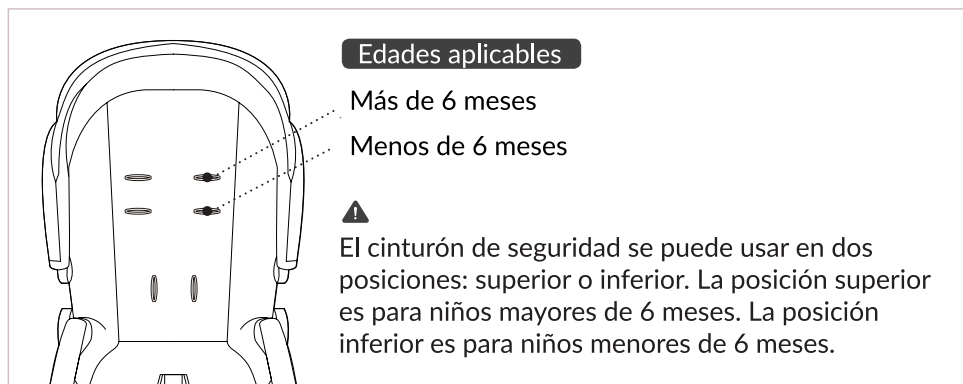

- 1** Inserte la parte b1 en la parte a1, inserte la parte b2 en la parte a2, un "clic" indicará que están colocadas correctamente.

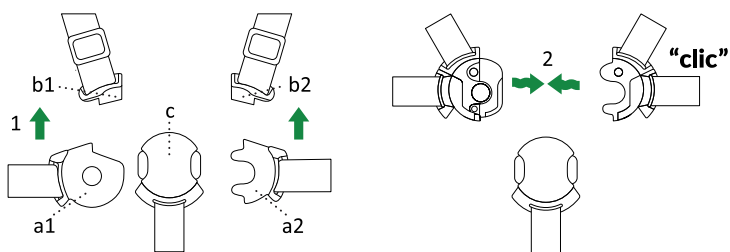

- 2** Coloque la pieza a2 sobre la pieza a1 y el componente de la hebilla "c", como se muestra en la imagen superior, sobre las piezas combinadas a1+a2. Un clic indicará que están correctamente fijadas.

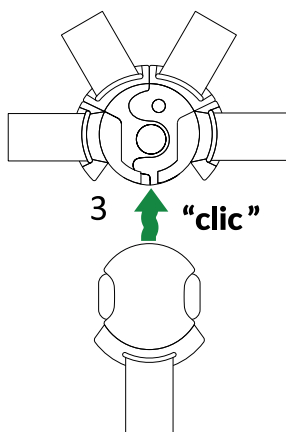

3 Para liberar la hebilla, presione los botones de cada lado.

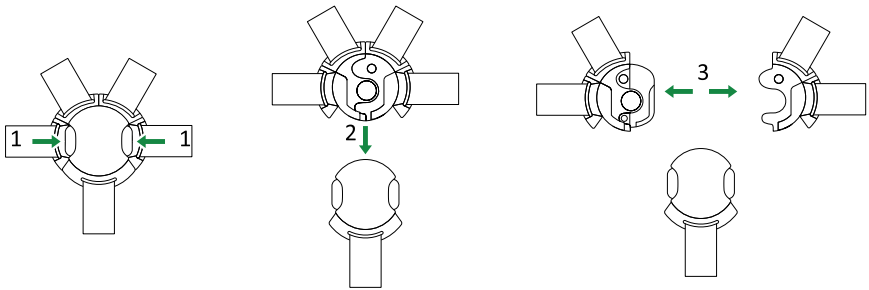

Plegar el cochecito

1

1. Incline el asiento hacia adelante

Como se muestra en la Figura **a**, tire de la palanca de ajuste del respaldo para girarlo hacia adelante y que se pliegue sobre el asiento (Figura **b**).

2. Baje el manillar y prepárese para plegar

Como se muestra en la Figura **c**, ajuste el manillar a su posición más baja. Luego, tire de los botones a ambos lados del armazón **d** y baje el manillar hasta el tope **e**.

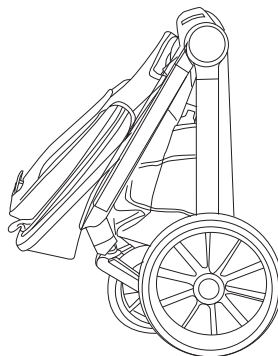
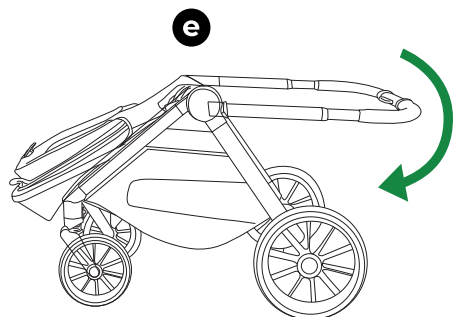
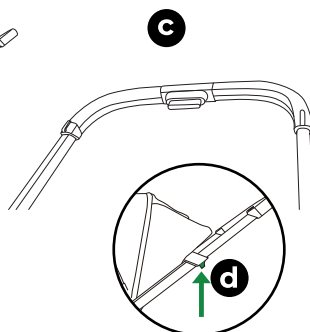
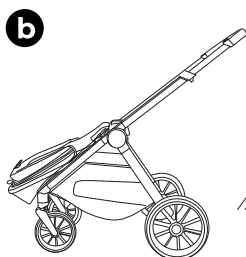
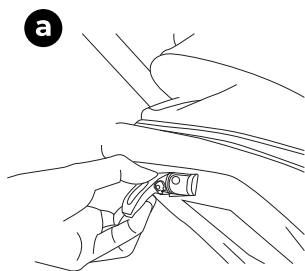

Adaptadores para asientos de coche

1 Conecte los adaptadores al portabebés

Coloque los adaptadores del asiento del automóvil en el lado correspondiente del portabebés.

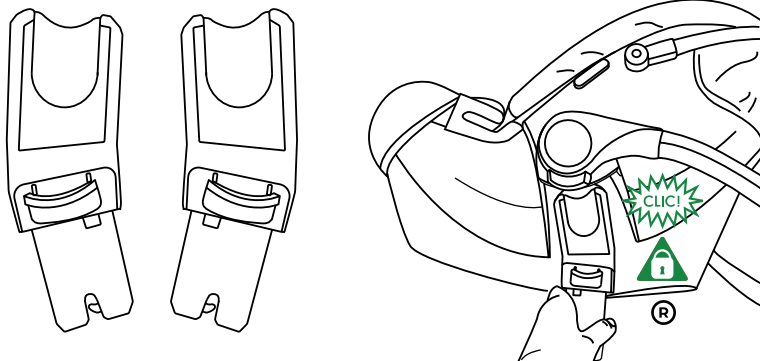

2 Coloque el portabebés en el marco

Coloque el portabebés sobre el chasis del cochecito, en la posición orientada hacia los padres, y bájelo sobre el chasis. Asegúrese de que ambos lados estén bien encajados. Compruebe que estén bien fijados antes de continuar.

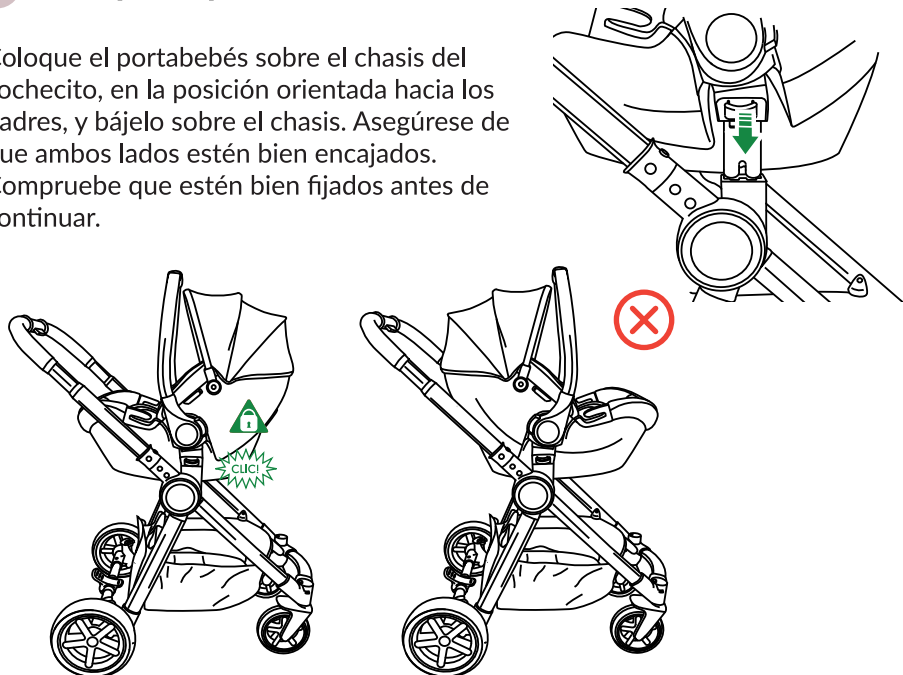

3 Retire el portabebés del marco

Levante los botones de liberación de cada lado y levante el portabebés del marco.

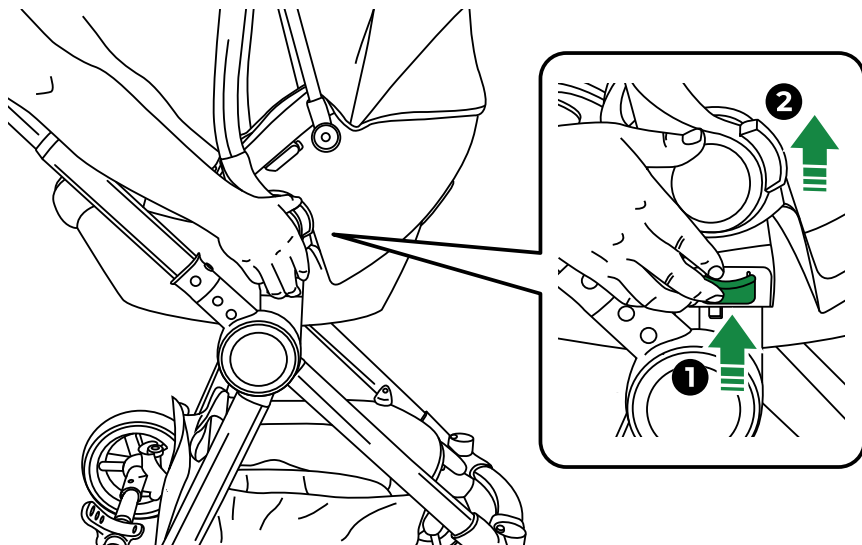

4 Retire los adaptadores del portabebés

Presione los botones de liberación del adaptador (1) en ambos lados superiores del portabebés para liberar los adaptadores.

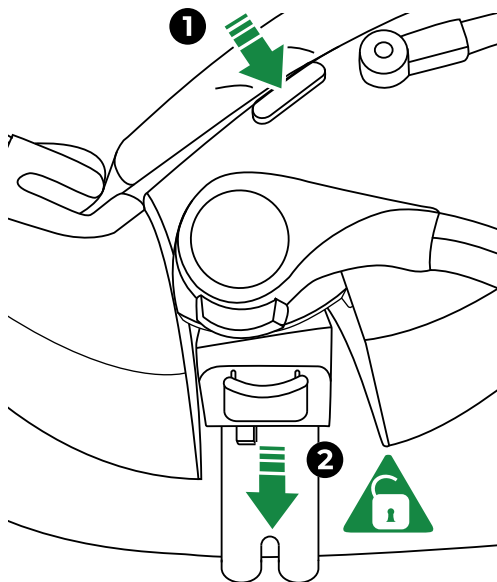

Cuidado y mantenimiento

- Compruebe periódicamente el correcto funcionamiento de los frenos, las ruedas, los cierres, los elementos de conexión, los cinturones y las costuras.
- No exponga la carriola a la luz solar directa.
- Límpiela solo con esponja.
- Después de usarla bajo la lluvia o la nieve, lubrique las ruedas y seque la carriola para evitar la oxidación.
- Cuide, limpie y revise esta carriola periódicamente.
- No utilice accesorios no aprobados por el fabricante.

La seguridad de su hijo es su responsabilidad.

Si tiene algún problema con este producto o necesita piezas de repuesto, visite www.mybabiie.com/support

Registre su producto en: www.mybabiie.com/warranties

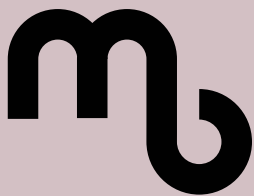

Register your product



www.mybabiie.com/warranties



www.mybabiie.com/registro

In the first instance of needing assistance please contact your original place of purchase.

This product qualifies for 12 month warranty when registered through our website

mybabiie.com



My Babiie



@MyBabiieOfficial



My Babiie



@mybabiie_official